

APRIL

1941

Radio

SERVICE DEALER

This Month

FM-AM INPUT FOR P.A.

STATIC ALIGNMENT

TUBE BIAS SYSTEMS

VOLTAGE DOUBLING

SHIP RADIO OUTLETS

PRICE

25¢





When You "Reset" or Repair Their "Big Sets"

THESE RADIOLA MODELS

SELL THEMSELVES

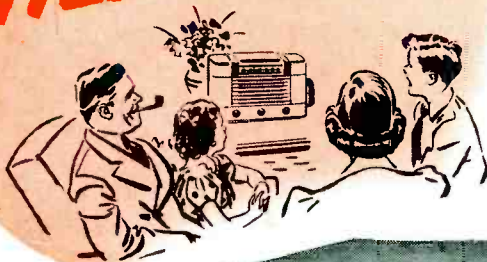

RADIOLA "Extra" Radios Mean Extra Sales... Extra Profits for SERVICEMEN

"JINX" FALKENBURG, America's Number 1 Model, poses with America's Number 1 profit-opportunity for servicemen... the new Radiola Model 515. Both "Models" have plenty of eye-appeal!

Successful servicemen are smart salesmen. That's why we designed a line of small, fine sets specifically for *servicemen* to sell.

Look at the RADIOLA 515 above. Suppose you leave it in a customer's home while their regular set is in your shop—or even just demonstrate it when you retune their radio push-buttons.

While *their* set is in your hands, your customers are discovering the added pleasure such an "extra" radio can bring. A radio they can carry easily from room to

room... a radio they can listen to at will. A radio with such top-notch features as *foreign reception*... R. F. stage for greater sensitivity... *six* RCA Preferred Type Tubes... continental-style wrap-around cabinet of costly woods... the RADIOLA 515!

Try it—see for yourself. Remember that your best service *customers* are your best RADIOLA *prospects*.

And that RADIOLA is especially designed to be sold by you. By you.



All RADIOLA Models Are Equipped Exclusively with RCA Preferred Type Tubes

SUPER-SELLERS, Every One!



RADIOLA Model 510... 1 C-volt AC-DC. Striking cabinet of molded plastic, with tear-drop knobs and attractive clock-type dial. Highly efficient chassis embodies superheterodyne circuit, built-in tuned loop antenna, full AVC action, 5" Electrodynamic Speaker, 5 RCA Preferred Type Tubes.



RADIOLA Model F-5... A 5-way portable that's a real eye-opener. Operates from self-contained batteries or 110 volt AC or DC line. Durable, washable simulated-leather covering. Built-in tuned loop. 5 RCA Preferred Type Tubes.

PLUS MANY OTHER FAST-SELLING MODELS

Radiola Preferred Type Radios

Made by RCA Manufacturing Co., Inc., Camden, N. J., U. S. A.
A Service of the Radio Corporation of America
In Canada, RCA Victor Company, Ltd., Montreal

Radio SERVICE-DEALER

SOUNDMAN AND JOBBER

Reg. U. S. Pat. Off.

Ad Index

Aerovox Corporation	34
Metal Can Electrolytics	
Belden Manufacturing Co.	29
Hookup Wires	
Brach Mfg. Corp., L. S.	35
Home & Auto Antennas	
Burgess Battery Co.	28
"A" and "B" Batteries	
Centralab	3rd Cover
Resistors	
Chanrose Radio	5
DeWald Receivers	
Cinaudagraph Speakers, Inc.	32
Cinaxial Speaker System	
General Industries Co.	32
C-120 Record Changer	
General Transformer Corp.	33
Porta-Power Units	
Howard Radio Co.	34
Model 718-FM Radio Chassis	
Hygrade Sylvania Corp.	30
Tube Complement Book	
Insuline Corp. of America	35
Radio Parts, Hardware	
International Resistance Co.	6
Type D Volume Controls	
National Carbon Co., Inc.	23
Mini-Max "B" Batteries	
National Union Radio Corp.	4th Cover
Battery Merchandiser	
Ohmite Manufacturing Co.	32
Resistors, Power Chokes	
Racon Electric Co.	2
Speakers and Horns	
Radio Parts Manufacturers	4
National Trade Show	
Radiotechnic Lab., The	36
Tube & Battery Tester	
Raytheon Production Corp.	9
Tubes in Steel Testing	
RCA Mfg. Co., Inc.	2nd Cover
Radiola Receivers	
Rider, John F.	33
Rider Manual Vol. XII	
Shure Brothers	30
Cardioid Microphones	
Solar Manufacturing Corp.	35
Quick-Check Analyzer	
Sprague Products Co.	31
National Defense	
Sundt Engineering Co.	35
Carillons, Musical Towers	
Supreme Instruments Corp.	25
Book, "Dynamic Analysis"	
Triplett Elec. Inst. Co., The	31
Instrument Inspection	
Utah Radio Products Co.	27
Vibrators	

Contents

Transients (Editorial)	
One Year Young	3
Parts Shortage	3
Disc Delivery	3
Television	3
FM-AM Input for Sound Systems ..	7
Serviceman's Diary	8
By J. P. Hollister	
RSD Window Placard	10
Simplified Servicing With L-C Checker	11
By L. H. Gardner	
Radio Outlets for Defense Ships ..	13
By Julius G. Aceves	
Technical Service Portfolio, Sec. X Biasing Methods	15
Set of the Month—	
RCA Victrola Model V-101	
19	
Circuit Court:	
Midget Phonograph	20
AC-Battery Phono	20
Four-Way Portable	20
Double-Up Circuit	20
Phono Connection	21
Cutter Transformer	21
Shop Notes:	
Farnsworth BT-52,-53,-54,-55,-56 Circuit Change	22
Farnsworth BK-77,-78 Circuit Changes ..	22
RCA 6SF7 & 12SF7 Tubes	22
RCA 6SN7-GT Tube	22
RCA RP-152,-153,-155 Changes	22
Silvertone 6306 Extended Range	22
Silvertone 6490-B Component Change ..	22
Wilcox-Gay A-89,-91,-92,-93,-94 Pickup Resistor	22
New Products	24
New Catalogs	35
News	36
Book Review	36

Cover Photo



★ We had a cake (and ate it, too) in celebration of our first anniversary. The one candle glows with pride, as can be seen in the photo. So do we (not shown in photo). Now we're working toward two candles—and then three, and so on. Sorry we couldn't pass the cake around, but it wasn't that big. Well, happy birthday to us!

Published Monthly by

COWAN PUBLISHING CORP.

11 WEST 42nd ST., NEW YORK, N. Y.

Telephone: CHickering 4-3278-9

M. L. MUHLEMAN, EDITOR

S. R. COWAN, ADV. MANAGER

Subscription rate, \$2.00 a year in United States. Single copies, 25 cents. In foreign countries and Canada, \$3.00 a year. Editorial and advertising offices, 11 West 42nd St., New York, N. Y. Chicago Office: Marshall Reing, 612 N. Michigan Ave. Tel.: Whitehall 4666.

VOL. 2 No. 4 ★ APRIL, 1941

for

Year 'Round Profits

in the Sound Business

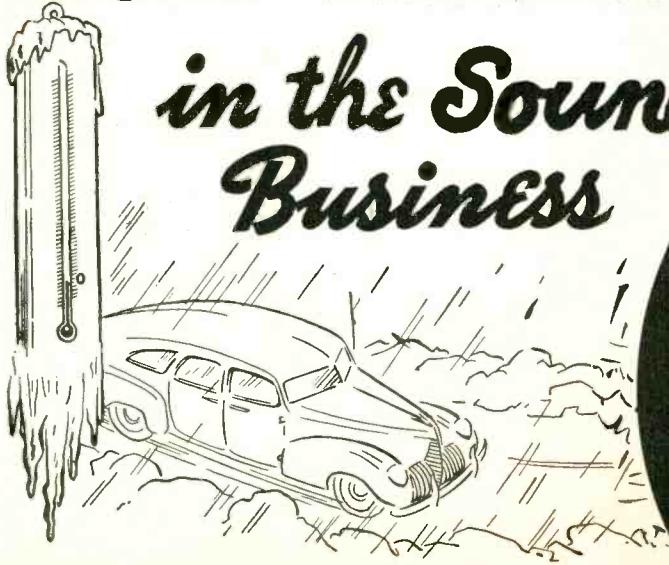

use
RACON
SPEAKERS
& HORNS

RACON speakers alone can afford peak efficiency regardless of changing climatic and atmospheric conditions. They were designed to do just that and the patented materials used in their construction are contributing factors.

RACON Storm proof, Break proof, Acoustic Material is your best insurance policy against all kinds of weather conditions. Fully covered by RACON patents this material is often emulated but cannot be duplicated by any other speaker manufacturer.

Only RACON speakers deliver maximum output and response for the size of driving unit used. There is a RACON speaker (and speaker unit) for every purpose . . . leading soundmen specify and use RACON's because they are dependable, efficient and competitively priced.

Ask your
Jobber for
a new
catalog or
write us
direct

RADIAL HORN SPEAKER

A 3 1/4 foot re-entrant type Radial horn designed to project sound over a complete circumference of 360°, distributing sound with an even intensity. For all sound installations where complete coverage is desired. Base and tone arm made of heavy aluminum castings, centre deflector and deflecting bells made of RACON ACOUSTIC material to prevent all resonant effects. Storm-proofed and guaranteed against all weather conditions. Uses Standard RACON Units.



RE-ENTRANT TRUMPETS

A compact trumpet of the double re-entrant type. Occupies but a small space, nevertheless has a long air column enabling it to deliver highly concentrated sound of the greatest efficiency over long distances. Base and inside cone arm made of aluminum castings, outside bell of heavy gauge aluminum spinning, center section of RACON ACOUSTIC material to prevent resonant effects. Available in 6', 4 1/2', 3 1/2' and 3' air column units.



RACON P. M. HORN UNITS

Operating capacity 12-15 watts, peak 25 watts. Other P.M. units available from "baby unit" of 5 watts to "bull unit" with an operating capacity of 50 watts. Efficiencies of the highest order obtainable with the finest magnetic material and steel utilized.



RACON ELECTRIC CO. 52 EAST 19th ST. NEW YORK, N. Y.

TRANSIENTS

ONE YEAR YOUNG

RADIO SERVICE-DEALER was inaugurated a year ago this month. The happy occasion entitles us to one candle which we shall proceed to burn at both ends for your benefit.

There is an old bromide specifically phrased for big moments in little histories of just this sort. It goes something like this: "We wish to express our gratitude to the many subscribers and advertisers who have given us their full-hearted support. Such progress as we have made in this first year we owe to them."

But it doesn't sound at all like a bromide to us, because we mean it and believe it. We are grateful, and rather happy, and if our expression of thanks sounds a bit too "old tie," we can't help it.

PARTS SHORTAGE

WE FIND IT necessary to mention again the possibility that there may be serious shortages in radio supplies due to national defense priorities. We urge all jobbers and servicemen to stock up now on parts and accessories before an actual scarcity develops. Many manufacturers have already ceased the handling of what might be termed "indiscriminate" orders, and that may be only the beginning.

"Business as usual" no longer holds in this country. The national defense movement is an all-out affair, and commercial needs are necessarily of secondary importance.

Due to the pressure of government business, the radio manufacturer can no longer maintain the involved and time-consuming bookkeeping necessary in the handling of thousands of little hand-to-mouth orders from jobbers and servicemen. This kind of business is no longer in the cards. It has to go.

Beyond this is the rumor from well-informed sources that present stocks of p-m speakers, aluminum-cased electrolytics, gang condensers and other such items, cannot be replenished. That remains to be seen, but don't ignore the gathering clouds and get caught in the rain.

DISC DELIVERY

FROM PRESTO RECORDING comes an interesting sidelight on the record blank business that is worth repeating. Seems that many servicemen are offering a home delivery service to users of home recording discs in their neighborhoods, and report a profitable business—particularly in the evenings and over week-ends when discs are unobtainable from local stores. Order cards mailed monthly keep the serviceman's phone number handy and help promote the business.

It's worth trying in your neighborhood. If you don't keep open shop in the evening and over week-ends, include your home phone number on the mailing cards and keep the family car handy.

TELEVISION

FROM WASHINGTON comes the news that the Federal Communications Commission and the radio industry agree that Television should be given commercial significance. Asked for at the hearings were definite standards and a go-ahead date.

With a lack of an eye-to-eye view on a few matters, Television still straddles the fence, but with no upset caused by the national defense program, the chances seem good for a start by Labor Day.

Television will give the radio industry a healthy boost. Servicemen in particular will find it a bonanza, as each receiver calls for special signal survey and antenna installation.

EDITOR

Come On

WORLD'S GREATEST RADIO PARTS TRADE SHOW!



Kee*p out of the Rut . . . Get a Fresh View of the Industry*

Step right up, ladies and gentlemen! It's the one and only chance you'll have this year to see your great and glamorous industry on dress parade. Thrilling! Exciting! . . . The meeting of old friends, making new acquaintances from the north, the east, the south and the west . . . Magnificent displays of the latest developments for the coming season . . . Convention sessions of vital importance . . . Conferences with your suppliers. Something doing every minute . . . never a dull moment . . . Prepare now to attend . . . Don't miss the World's Greatest Radio Parts Trade Show!

Stevens Hotel, Chicago

JOBBER DAYS

start at 2:00 p.m. Tuesday,
June 10 and run to 6:00 p.m.
Thursday, June 12.

RSA SPECIAL PERIOD

Thursday, June 12, 6:00 p.m.
to 10:00 p.m.

OPEN HOUSE

Friday, June 13, 11:00 a.m.—
8:00 p.m.

Radio Parts National Trade Show

Sponsored by Radio Manufacturers Association and Sales Managers Club
Executive Office • 53 WEST JACKSON BOULEVARD • CHICAGO

DEWALD 1941 Models

sold in lots of 1 or 3 (or more)

at exceptionally low **NET PRICES**
direct from **Distributor to YOU**



Model 565—AC-DC, Battery Superhet

Versatile, compact, 3-way portable. Streamlined luggage construction with completely concealed radio unit; easy slide disappearing lid cover; choice of 2 coverings—natural and alligator with contrasting simulated leather tuning panel.

Advanced super-het circuit; 5 low drain tubes; built-in Looptenna; AVC; beam power output; large PM speaker. Many other features.

Retail list price \$24.95

Your net price each \$16.75

YOUR NET PRICE EACH LOTS OF 3

\$15.95



Model 670—3-Band AC-DC Superhet

Latest style tilt-top, easy vision slide-rule dial model in beautiful hand rubbed cabinet. Band spread tuning on two short wave bands; Tuned RF stage on all bands. Advanced superhet circuit; 6 low-drain single ended tubes; built-in Looptenna; large PM dynamic speaker; AVC; beam power output; variable tone control; built-in Wave Trap Code rejector.

Retail list price \$33.50

Your net price each \$20.95

YOUR NET PRICE EACH LOTS OF 3

\$19.95

We are now prepared to supply every legitimate Radio Service Dealer with any type brand new 1941 factory cartoned DeWald receiver in any quantity desired.

Our policy is timely . . . geared to present day conditions. Every radio service dealer stocks, sells and rents Nationally Known Brands of receivers. There is no finer line than DeWald . . . and at the especially attractive **LOW NET PRICES** quoted here you can't go wrong. Hundreds of our local service dealer accounts will attest to that.

We sell at wholesale only, give factory guarantees, do not require a franchise or contract for a specified number of receivers. We have sufficient stocks on hand to meet your requirements . . . most important, all merchandise is shipped on the same day that order is received.

Send for literature describing the many new 1941 DeWald receivers not illustrated here. List prices range from \$9.95 to \$149.50 . . . net prices are much lower.

20% deposit required with order. All prices quoted here are NET, F.O.B. Jamaica, New York. Save 2%, send check or M. O. with order.

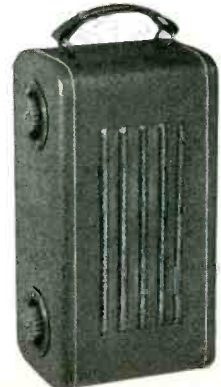

Model 410 Battery Miniature "COMPANIONETTE"

Streamlined 4 pound personalized model in beautiful simulated cowhide leather case with saddle stitching. One of the best sellers in the field.

4 tube superhet; PM dynamic speaker; AVC; iron core high gain IF transformer; self-contained Looptenna; uses 2 flashlight cells for "A" supply. Gives long battery use; has easy vision tuning dial. Tunes 1700 to 540 kc.

Retail list price \$19.95

Your net price each \$12.95

YOUR NET PRICE EACH LOTS OF 3

\$12.45



Model 562 AC-DC "JEWEL" Series

Five rich jewel-like Catalin colored cabinets that emulate precious stones to choose from: Model 562-AI, Alabaster with Ivory trim—Model 562-AB, Alabaster-Blue trim—Model 562-OB, Onyx with Ivory trim—Model 562-MI, Maroon-Ivory trim.

5 new type high-efficiency single ended tubes; advanced superhet circuit; new tilt-top easy-vision slide rule dial; high ratio Vernier Tuning; AVC; beam power output; large dynamic speaker; built-in Looptenna; tuning range—General Broadcast and Extended State Police Bands.

Retail list price \$19.95

Your net price each \$12.95

YOUR NET PRICE EACH LOTS OF 3

\$12.45

CHANROSE RADIO

[WHOLESALE ONLY]

170-16 JAMAICA AVENUE

JAMAICA, NEW YORK

RADIO SERVICE-DEALER, APRIL, 1941

"THE Easiest SHAFTS IN THE WORLD TO INSTALL!"



**TAP-IN
SHAFTS
STAY
PUT..**

and here's why!

IRC Tap-in Shafts won't slip or vibrate loose. The shaft socket is carefully gaged to a standard Brown & Sharp taper and the shaft taper is accurately machined to such a smooth, close fit that the surfaces are practically bonded together when engaged by a few taps of a hammer. This taper-socket principle is standard practice in machine tool work—from screw machines to giant lathes—where cutting tools for high speed or rugged work must be held securely in place.

NEW DOUBLE-FLATTED TYPE "A" SHAFT ELIMINATES INSERTS and FILING



This isn't our verdict . . . it's the verdict of thousands of servicemen who have found the Tap-in Shafts of IRC Type D Controls the answer to countless problems. They save your time—they save you money. Tap-in shafts make it possible to handle the big majority of all replacements with only a small stock of controls. They frequently enable you to use a standard Type D Control instead of a more costly, hard-to-get "special." Flats are easily located in any desired position. Shafts can be inserted *after* the control has been installed. It's unnecessary to remove other parts when making an IRC replacement in a crowded chassis. Once inserted, and tapped solidly in with a hammer, the shaft *is there to stay*. You don't have to fiddle with lock washers to hold it in place.

Don't fail to examine Type D Controls the next time you visit your distributor . . . and be sure to ask him about the IRC Master Radiotrician's Control Cabinet with its stock of only 18 Type D Controls, 6 switches and 5 special Tap-in Shafts that handle from 60% to 75% of all replacements!

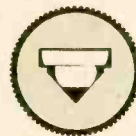

Shaft position in knob requiring 3/32" flat.



Shaft position in knob requiring 1/32" flat.

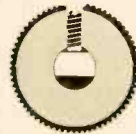

How shaft is positioned for set-screw knob.



Only edges of shaft are filed for odd types.

Here's the answer to simplified fitting for *all* knobs. No more bothersome metal inserts necessary . . . shaft filing eliminated for all 1/4" or 3/8" standard flats . . . easier-to-cut to length, too.

IRC TYPE D UNIVERSAL VOLUME CONTROLS

INTERNATIONAL RESISTANCE CO., 401 N. BROAD ST., PHILA., PA.

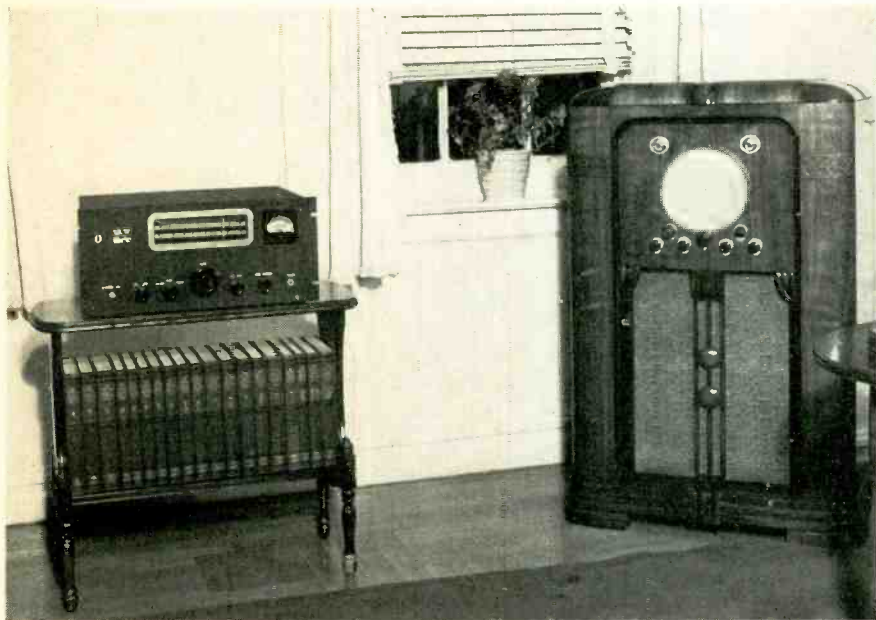

THE FM-AM TUNER IN THE HOME

AN FM-AM INPUT FOR SOUND SYSTEMS

THERE are many types of sound installations which will benefit from the introduction of f-m broadcasting—a fact which provides dealers and sound-installation specialists with new and distinctly worthwhile sales opportunities.

There is no need here to review the advantages of f.m. from the standpoint of the listener, but it may be of interest to briefly mention the practical advantages from the standpoint of certain types of p-a prospects.

F-M PROSPECTS

So far as schools are concerned the importance of f.m. is best indicated by the fact that the FCC has set aside five f-m channels exclusively for educational broadcasting—about 11% of the entire f-m broadcast range. This provision will undoubtedly result in a considerable extension of educational broadcast activities and will make radio a more important tool of education than heretofore.

Studies in musical appreciation have been an important factor in school broadcasts for some years now and many schools have installed sound systems primarily for the purpose of taking advantage of this extension to their normal music studies. It goes without saying

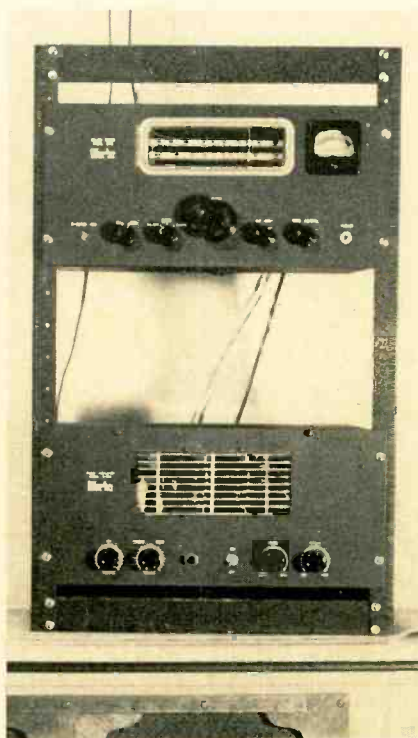

The Tuner in relay rack with special wide-range amplifier.

that the superior fidelity and the improved dynamic volume range of the f-m stations will make it easy to sell f-m tuners for use with such existing systems—and easier to sell!

complete sound installations where none now exists.

In many institutions musical programs are preferred and experience to date indicates that f-m broadcasts will provide proportionately more of these than do the regular a-m stations. This will also be an advantage to restaurants and other assemblage places where the sound system is primarily employed to provide a musical background.

In industrial installations it has been demonstrated time and time again that the general distribution of radio programs has resulted in better work and increased production. For these, f.m. offers a new freedom from electrical noise disturbances—an obstacle that has in many plants made the use of radio input equipment impossible in the past.

This freedom from most of the more common types of radio noise interference offers advantages in every type of installation, particularly those in congested downtown areas where electrical equipment, flashing signs, etc., create a noise level that a-m receivers find it difficult to surmount.

Where radio reproduction is offered as a service to customers, as in centralized hotel systems, res-

(Continued on page 23)

Serviceman's Diary

J. P. Hollister

FRIDAY—It happens to us—it must happen to you too. We run along for days, maybe weeks, knocking over one job after another so easily that we begin to think we're good. Then, all of a sudden, we get ourselves stuck with a batch of lousy intermittents. You know the kind—the set goes sour on Mondays, Wednesdays and Fridays, and usually in the customer's home, right after you've delivered it as fixed.

Yeah—we know all the answers too. Nine out of ten of them can be made to cut out if you sock the chassis with the butt of your hand, or if you tap the tubes with a rubber mallet, or if you tickle the tubulars, or if you snap the power on and off suddenly, raise and lower the line voltage quickly, or if—but what's the use? Nine out of ten may respond to treatment, but somehow it seems that somebody else always gets the nine which will, while we get the one which won't. As, for instance, right now.

Prize lemon of a group of four

is a Motorola 89K2, now an unwelcome guest of our establishment. I brought it in originally. I admit it. I did it with my eyes open. I knew what I was letting myself in for. But you would have done the same.

When the old lady first called up, I had a feeling there would be trouble. The family never spent a dime with us before, despite the fact that we've got customers—good boosters, too—living next door to them. We weren't the only ones who didn't get their trade. In fact, practically everything they bought came from the city, except food and drugs. Not that we cared too much; (the rich are seldom good customers for radio servicing) but it does help to mention to other snooty customers that you have so-and-so on the books—particularly if so-and-so happens to be a little better off than your snooty prospect. So I was kind of glad to get the call.

It was bad, right from the start. Before I got my coat off she was

handing me a line which sent the cold shivers up my back. Of course, she told me, she was only too glad to patronize the community tradespeople, but most of her requirements were of such a specialized character that she feared to let anyone but experts handle her work. Especially since her husband was so particular. But this job was different. After all, if it had been the Capehart she would have been obliged to call in her regular man, who was a real engineer from the city and very expensive. But this was only a small console and, really, there was nothing very much wrong with it. Only, occasionally, on certain programs, it seemed to get weak. Perhaps it was only a tube. Would I look it over, and quickly, please, because she had guests coming soon. And she swept out of the room before I had a chance to get a word in edgewise.

So I gave it the works. Found nothing wrong, of course, and sent in word by a maid that the set would have to go to the shop, and that I would like to discuss the matter with her. No use—she simply sent word back to do whatever was necessary.

And now it's on the bench, playing softly, sweetly—and continuously! Every form of mental, moral, scientific and physical persuasion has been tried in an effort to get it to fade or cut out, but it won't. And they want it back pronto.

Jerry poked his head in the shop. "Still fiddling around with the Motorola?" he said. "Why not rest up for a minute and take a look at the tank?"

He's nuts about tropical fish. He keeps them in the back room and, to my mind, hangs around them altogether too much.

"Listen, guy!" I told him, "This job is rush and I've got no time for your fish."

"Aw, come on," he coaxed. "They never cut out if you look at 'em!"

That made sense. So I went back with him. The tank did look nice, the muddiness having cleared up completely. He told me he'd put a pinch of permanganate of po-

(Continued on page 30)



STEEL BARS **SHATTERED** IN SECONDS

WITH **RAYTHEON** TUBE EQUIPPED
TESTING APPARATUS!

Every day in the testing laboratories of steel plants, turning out vast quantities of defense material, a continual fatigue-strength test of steel goes on. The Rayflex Fatigue Testing Machine meets industry's demand for the most scientific procedure to accurately conduct these tests.

The Rayflex machine vibrates a specimen bar of steel by the means of electromagnets actuated from an oscillator-amplifier combination with frequencies varying from 6,000 to 18,000 cycles, condensing all the wear of years into a matter of minutes! You would expect the control apparatus of Rayflex to be equipped with the best and most dependable tubes money could buy . . . tubes that must not fail under the exacting conditions of these essential tests.

You will find RAYTHEON RADIO TUBES performing this difficult task for Rayflex with the same consistent high quality performance that they have always given to radio dealers and servicemen. No special tubes were developed for the Rayflex machine . . . it uses the same standard RAYTHEON RADIO TUBES that are sold by thousands of radio dealers and servicemen every day.

Your RAYTHEON Distributor has an unusual tube deal for you . . . see him today . . . Remember, RAYTHEONS cost no more for their plus advantages.

Raytheon Production Corporation, Newton, Mass., New York, Chicago, San Francisco, Atlanta.



WORLD'S LARGEST EXCLUSIVE RADIO TUBE MANUFACTURERS
RADIO SERVICE-DEALER, APRIL, 1941

Your Radio



Is Also

UNDER BOMBARDMENT



Electrons Continually Smash At The Vital Parts In Your Receiver

Invisible though they are, electrons develop "electrical friction" in your radio, just as the moving parts in your car develop mechanical friction. The unceasing flow and bombardment of these tiny electrical particles create heat that brings on the deterioration of tubes, condensers, resistors and other components.

Because of this invisible wear on parts, your radio should be checked periodically if serious breakdowns are to be avoided. The Certified Radio Service-Dealer in your community can be relied upon to do this work effectively and economically. Have your set checked now so that you may enjoy perfect reception during the summer.

Electron Bombs "Soften Up" These Parts—Hasten Their Failure

CONTROLS

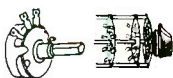

RESISTORS

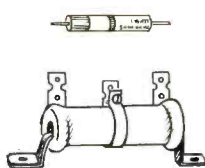

BATTERIES



COILS

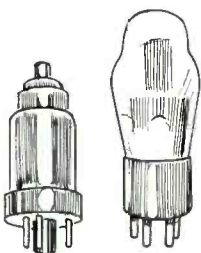
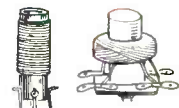

RADIO TUBES

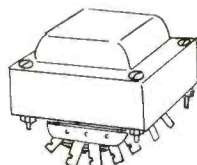

TRANSFORMERS

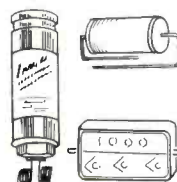

CONDENSERS

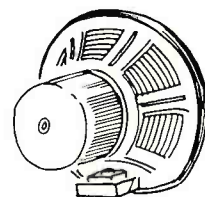

LOUDSPEAKER

SIMPLIFIED

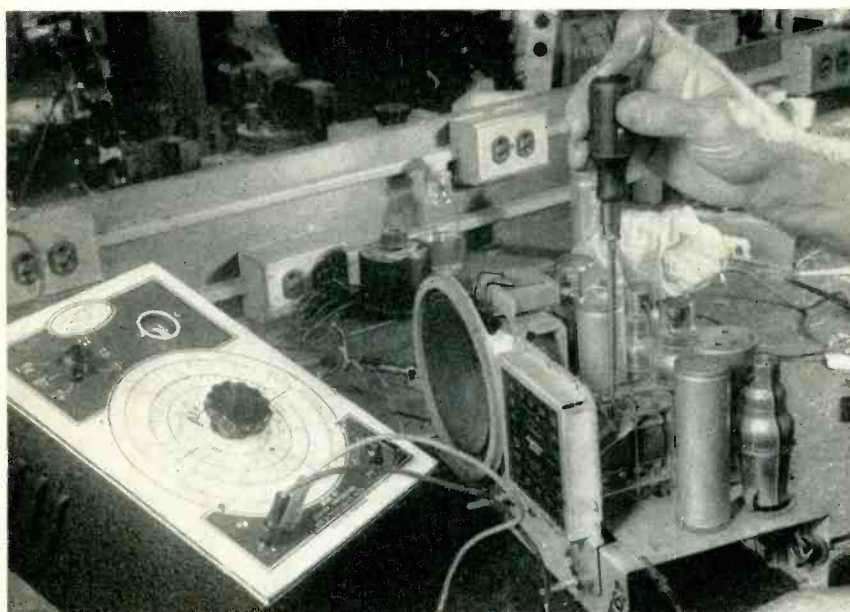

THE L-C CHECKER IN USE

SERVICING WITH L-C CHECKER

L. H. Gardner

Engineering Department, Aerovox Corporation

FREQUENCY reallocation has built up a huge backlog of repair and alignment work for the coming months. Checking alignment of r-f circuits, tracking oscillators, aligning i-f circuits and checking frequency ranges calls for modern and highly efficient equipment. Such a piece of equipment is the L-C Checker. This instrument can, with a high degree of technical perfection, be utilized for the following:

1. Measurement of capacity.
2. Measurement of resonant circuits.
 - A. Determining frequency of i-f transformers.
 - B. Determining location and frequency of absorption loops in r-f equipment.
3. Determining resonant frequencies of r-f chokes.
4. Checking alignment of r-f circuits and tracking the oscillator.
5. Checking the frequency ranges of radio receivers.
6. Checking the frequency ranges of signal generators.
7. Alignment of receivers.
 - A. Alignment of r-f circuits of a receiver (with power off).
 - B. Alignment of i-f circuits of a receiver (with power off).
 - C. Determining which circuits of a receiver are out of tune (with power off).
8. Measurement of inductance, including the distributed capacity of the

coil under test.

9. Measurements of antennae and transmission lines.

A. Measuring fundamental frequency of the antenna.

10. Checking wide-range r-f filters.
11. Checking wavemeter calibration.
12. Tuning of wave traps.

There are innumerable other uses for the L-C Checker, but in connection with frequency reallocation, the foregoing list fulfills the radio serviceman's requirements.

REALLOCATION CHECKING

Reallocation has had its attendant problems. For instance, if a station of strong signal intensity is operating on double the frequency of the i-f of a receiver, there is liable to be a heterodyne whistle. Most servicemen are familiar with the fact that 455-kc is used as the standard i-f on receivers manufactured in this country. Due to the reallocation of frequencies, some American broadcast stations have been assigned to 910 kc. In cities where these transmitters are located, the heterodyne whistle will be quite apparent. If a heterodyne note is heard, due to

this situation, the remedy is to shift the i-f of the receiver to one side or the other. Even though a receiver has an i-f of 455-kc, the heterodyne oscillator may be off enough to cause the same whistle from a station operating on a frequency of 920 kc. In this case the same procedure is followed, i.e., the i-f is shifted to one side or the other.

The standard broadcast range has been extended from a high-frequency limit of 1500 kc up to 1600 kc. In the majority of receivers not covering this tuning range, it is probable that the range can be extended so as to include 1600 kc by shifting the i-f and by changing the trimmers on the gang condenser. Receivers that will not tune to 1600 kc after the foregoing operations have been completed, necessarily must be converted if the owner wishes to include 1600 kc. To determine this by using the L-C Checker is a simple operation. Tune the L-C Checker to 1600 kc and, with the proper values of padding condensers installed in series with the main gang condenser, both the i-f and the padders should

be adjusted until the receiver is in a resonant state with the L-C Checker.

ALIGNMENT AND TRACKING

The L-C Checker can be used successfully to check the alignment of r-f circuits and to check the tracking of the oscillator.

In checking alignment of r-f circuits and tracking of the oscillator, the following points should be remembered. It is usual to set the conversion oscillator to a frequency higher than the signal to be received by the amount of the i-f frequency, and it should approximate this relationship as closely as possible throughout the tuning range if the tracking of the oscillator is to be correct. The necessary steps are usually as follows:

1. Determine the i-f by placing the capacity test prod on the i-f grids and then hunt for a frequency which gives an indication on the L-C Checker. Usually the i-f is marked; in some cases it is safe to guess, if the i-f is badly off. In a particular case, it was found that the last i-f transformer was set at about 380 kc and the trimmer screws were down very tight. After loosening them a turn or two, it was found that the i-f could be peaked nicely at 450 kc.

This can all be done with the receiver turned off. The i-f can be

tuned first on the grids, diode plates, and then on the plates, by setting the L-C Checker on 450 kc and connecting the ground to the set chassis, using a short lead from the upper "capacity coupling" terminal as a test probe on the various grids, plates, etc., and in each case tuning for an indication on the 6E5. If it is not possible to shift a broad-band i-f over to the sharp position for alignment, it is advisable to short the plate to ground (of course the receiver is not turned on) while aligning the grid, and to short the grid to ground while aligning the plate to prevent too much interaction between plate and grid tuning.

2. The frequency range of the receiver can, in most cases, be determined from the dial scale. Let us assume the range is 550 to 1600 kc. Then adjust the r-f trimmers until the indication at 1400 kc comes in at the right spot on the dial; then the receiver dial should be turned to 600 kc, and the resonant frequency of the r-f and antenna circuits re-checked. If it checks reasonably close, about 3 or 4%, this may be accounted for by the small capacity of the capacity probe in shunt with the tuned circuit, and this small error will be corrected later. If the r-f circuits do not check this close, either the coils were not correctly designed originally or the gang condenser has been thrown out of wack.

3. Once the r-f circuits have been straightened out, we know the correct frequency range which the conversion oscillator must cover. In the example, (2), it would be 550 plus 450, or 1000 kc to 2050 kc.

The first thing to do is rotate the gang condenser on the receiver to 1400 on its scale setting, then set the L-C Checker on 1850 kc. (1400 plus 450) and adjust the shunt padder on the oscillator until the oscillator circuit is resonant at 1850 kc. Next, rotate the receiver dial to 600 (or the setting at which 600 was found for the r-f circuits) and set the oscillator by means of the series padder to 1050 kc. Now return the receiver dial to its 1400-kc setting and check the oscillator circuit for 1850 kc again. It may be necessary to make a slight readjustment of the shunt padder; then set the receiver on 600 kc again and readjust the series padder to 1050 kc. This process should be continued until the oscillator covers the range accurately, at least at those two points, 1400 kc and 600 kc.

4. At this time we are ready for the final adjustment. The receiver must be turned on and the capacity prod removed from the L-C Checker. A lead should be connected to the gang of the first detector tube and held within about a half-inch of the top capacity coupling binding post.

If the receiver has a rather high gain i-f, a certain amount of hiss should be heard as the L-C Checker is tuned back and forth between 440 to 460 kc. The i-f can be aligned by adjusting the trimmers for maximum hiss at 450 kc when the L-C Checker is used as an unmodulated signal source of this frequency.

If the i-f does not have enough gain to produce any appreciable hiss, it should be possible to tune in some strong broadcasting station and tune the i-f for maximum response to that station. This final adjustment of the i-f should require only a very slight change in the trimmers.

The exact i-f frequency can be determined by coupling the L-C Checker to the first detector grid and zero beating the i-f frequency. If it is desired to adjust the i-f to a slightly different frequency, the L-C Checker should be set to that frequency, i.e., 450 kc—then the receiver dial should be rotated slightly to reduce the audible beat between the converted signal frequency and the L-C Checker to zero. Now the i-f trimmers should be readjusted for maximum output, after which the receiver i-f is accurately aligned.

A station around 1400 kc should next be tuned in and the oscillator shunt padder adjusted until the receiver dial reads this particular frequency correctly. If no station is available, the noise associated with tuning in the L-C Checker can be used, if the Checker is coupled rather loosely to the receiver. This is done by placing the L-C Checker some distance from the receiver.

After the oscillator has been adjusted to give the correct dial setting for 1400 kc, the r-f circuits should be aligned with a short antenna to give maximum noise or signal.

The receiver dial should next be turned to about 600 kc. Here the series oscillator padder should be adjusted slowly while the gang condenser is rocked back and forth for maximum output. The oscillator should be checked again at 1400 kc and at 600 kc until the

(Continued on page 31)

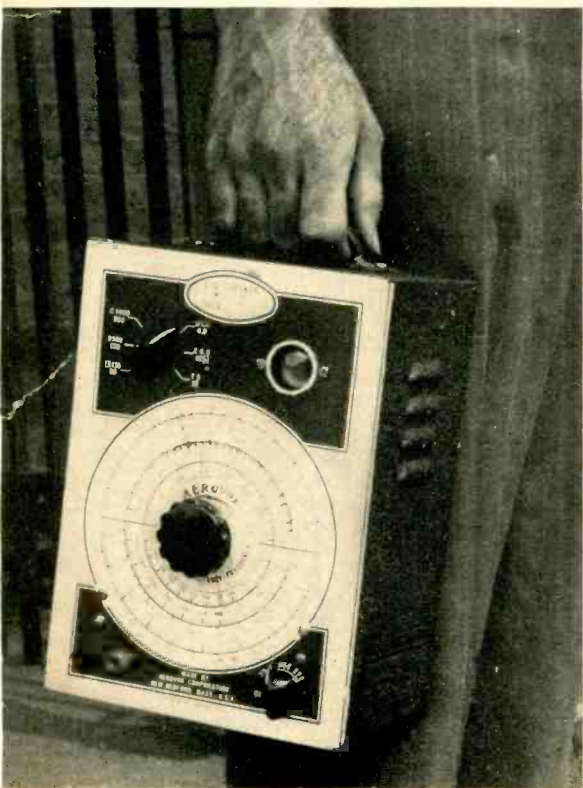

Radio Outlets for Defense Ships

Julius G. Aceves

Amy, Aceves & King, Inc.

Radio outlet in crew's stateroom aboard a tanker.

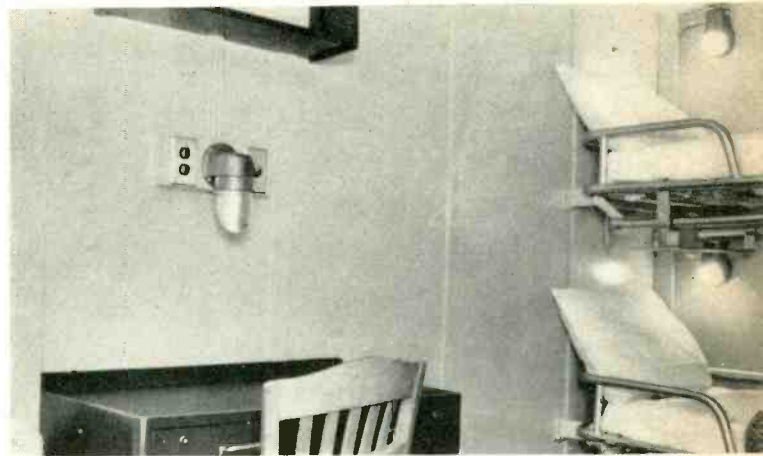

SAILORS, too, are radio enthusiasts. In port they listen in on the local broadcast stations. Far out at sea they depend on short-wave transmissions. However, sailors cannot take their radio entertainment for granted. No indeed. There are many complications in the way of satisfactory reception. But those complications, fortunately, are now being solved by the multicoupler-antenna system in marine dress. Our seafaring men

now look for those handy radio outlets which take the plugs of their private radio sets, among the many comforts and conveniences which make the American merchant marine the envy of sailors the world over.

Why the need for radio outlets and radio wiring aboard ship? Why can't the usual portable receiver or midget be used with its own built-in aerial or loop? Why all this fuss?

SHIP AERIAL PROBLEMS

To landlubbers who take radio entertainment as a matter of course, such questions come quite naturally. However, a seafaring man knows better, especially after he has tried to use a portable set or midget on shipboard. Here's why:

Due to the steel hull and other masses of metal aboard ship, the radio receiver is pretty well shielded from radio waves. Especially so when the ship is some distance out and the main reliance is on short-wave transmissions. Also, there is much electrical equipment aboard ship, causing no end of man-made static or background noise if radio signals are contrastingly weak. Therefore, an external aerial is essential for satisfactory reception, regardless what the set may be.

So the seagoing radio enthusiast decides on an external aerial. And that's precisely where his troubles begin. If he tries to put up his own private aerial above decks, he may find himself in a first-class feud with the skipper who objects to (1) having the rigging converted into a further jungle of wires, insulators, spreaders and whatnot, and (2) having his radio direction finder thrown off by the proximity of such aerials.

Still, your modern sailor feels entitled to radio entertainment, and his desires must be considered in these days of better living. And so the problem has been put up to ship owners and operators, who in turn have passed it on to marine architects for transmission on to us who are engineers specializing in antenna matters.

Obviously, satisfactory individual or private radio reception on shipboard calls for the multicoupler-antenna system technique. A single doublet type aerial,

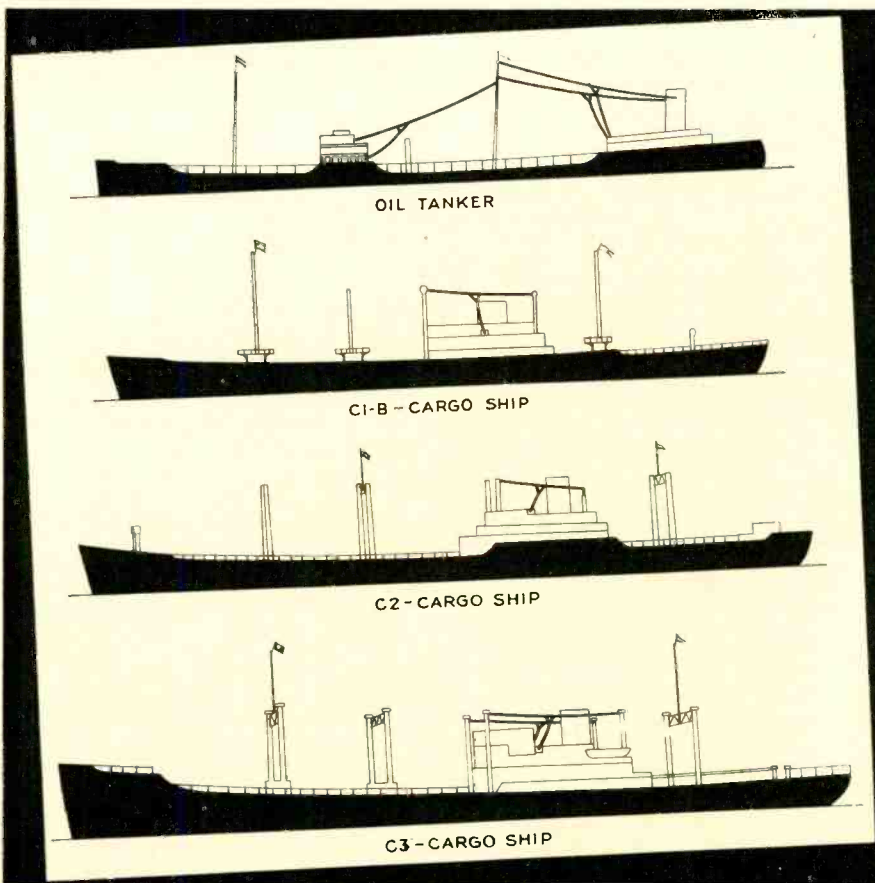

Typical installations. On C1-B and C2 cargo ships, two aerials are required; only one is shown in each case.

through suitable antenna transformer, set couplers and outlets, serves up to twenty-one receivers at maximum efficiency and with minimum background noises, and free from interference between sets. This idea has long since passed the experimental stage, since hundreds of apartment houses enjoy the ideal reception provided

by multicoupler-antenna system outlets.

ADAPTING THE SYSTEM

In adapting the multicoupler-antenna system to shipboard, we were faced with several new conditions. First, there is the steady vibration, which calls for stronger materials and joints. Second, there

are the high winds and sleet, requiring an aerial in strict accordance with the best marine radio standards. Third, corrosive influences such as salt air and funnel fumes must be countered by using anti-corrosive materials. Fourth, the heavy charges induced in the aerial by the nearby ship's trans-

(Continued on page 28)

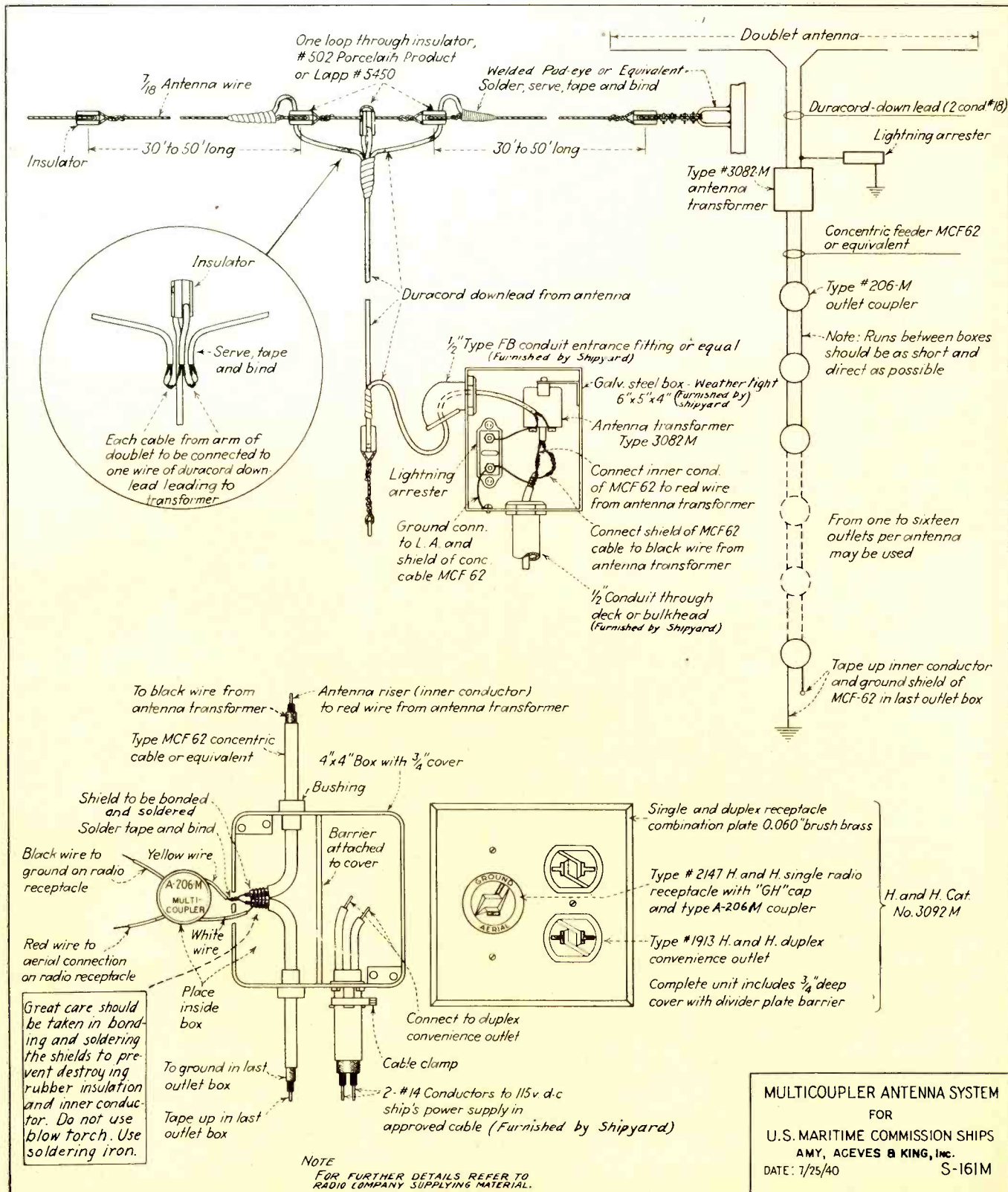

TECHNICAL SERVICE PORTFOLIO

SECTION X

BIASING METHODS

FOR PROPER operation, each amplifying tube in a radio receiver commonly requires a negative grid bias. This bias voltage serves to prevent the grid from becoming positive when a signal voltage is applied, and thus eliminates any loading effect on the circuit which would otherwise occur. If the bias voltage is increased beyond the normal operating point, the amplification of the tube and its circuit is reduced, but a higher signal voltage may be applied to the grid without causing the grid to draw current. This method of controlling amplification and signal-handling ability is employed in automatic control systems, such as AVC. The bias voltage not only controls the amplification of the tube and circuit; it also regulates the current flow in all the other tube circuits. Because it reacts upon other circuits in this manner, troubles in biasing circuits of modern receivers are often difficult to localize; every circuit we test seems to be affected when the grid bias is wrong. Further, many of the methods employed in applying grid bias to amplifying tubes are by no means simple, and, in view of the vital effect of this voltage upon performance of the receiver, we are devoting this section of the Portfolio to such biasing methods.

But first let us start with some of the simpler circuits. And, before we go any further, let us make clear that when we speak of a negative bias, we mean negative with respect to the cathode, in tubes employing heated cathodes.

If a filament-type tube is under consideration, then the bias is referred to the negative leg of the filament. When the filament-type tube is operated with a.c. on the filament, the bias is referred to the center tap on the filament winding of the transformer employed; or, if a center-tapped resistor is used for the purpose, to center tap of the resistor.

BATTERY BIAS

Two of the simplest methods of applying grid bias are shown in Figs. 1-A and 1-B. In each case the bias battery positive terminal

connects to the cathode or the negative filament, so the grid bias is equal to the battery voltage. In Fig. 1-C, however, though the battery voltage is the same, and the rated bias, based on the return being made to the center tap of the filament transformer, is 3 volts, as in the circuits of Figs. 1-A and 1-B, the actual bias is less. This is because each leg of the filament, being heated by a.c., becomes alternately positive and negative by an amount equal to the filament voltage—1.5 volts in this case. Therefore, the center-tap return corresponds to one-half the total fila-

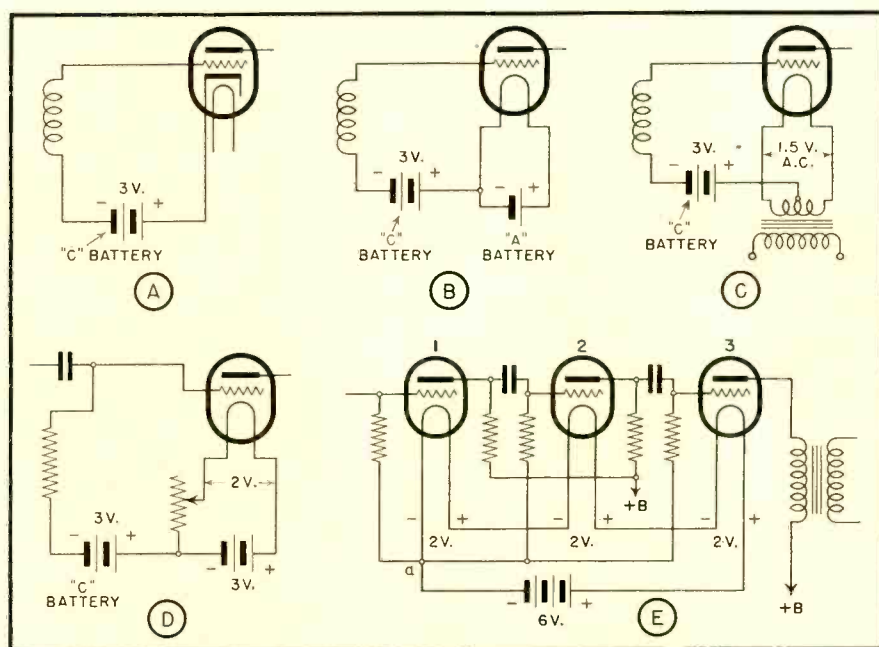

Fig. 1. Battery bias systems.

ment voltage, or $\frac{3}{4}$ volt, and the actual bias is less than the battery voltage by an equivalent amount. Thus, with the constants given, the effective bias on the grid is $-2\frac{1}{4}$ volts, and not -3 volts, as in the previous instances. In tube manuals, you will note that frequently the bias specified for filament-type tubes for a-c operation is accordingly increased so that the effective bias may be the same for both methods of operation.

In Fig. 1-C, the return to the filament was made through the transformer winding; in Fig. 1-D, the return to the negative filament is made through a rheostat. In the latter case, since the 3 volts of the A battery supply is reduced to 2 volts by the rheostat, there is a voltage drop of 1 volt across the rheostat. This, in effect, adds a volt to the C battery, so the effective grid bias becomes 4 volts instead of 3 volts. If the rheostat had been placed in the positive leg, the C battery could be returned to the negative A battery terminal without changing the bias.

When the filaments of tubes are connected in series, and the grid return is made to some point along the string, the bias may be obtained as illustrated in Fig. 1-E. Note that, while all the grids return to the same point a, the bias applied to each grid is different. Thus, for tube 1, the grid returns directly to its own negative filament terminal and accordingly the grid bias is

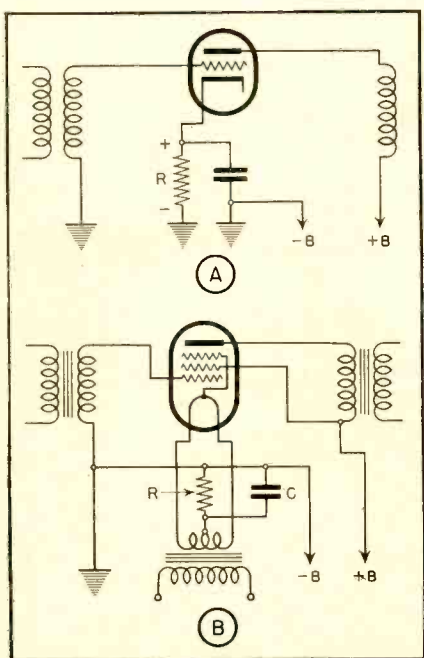

Fig. 2. Cathode bias.

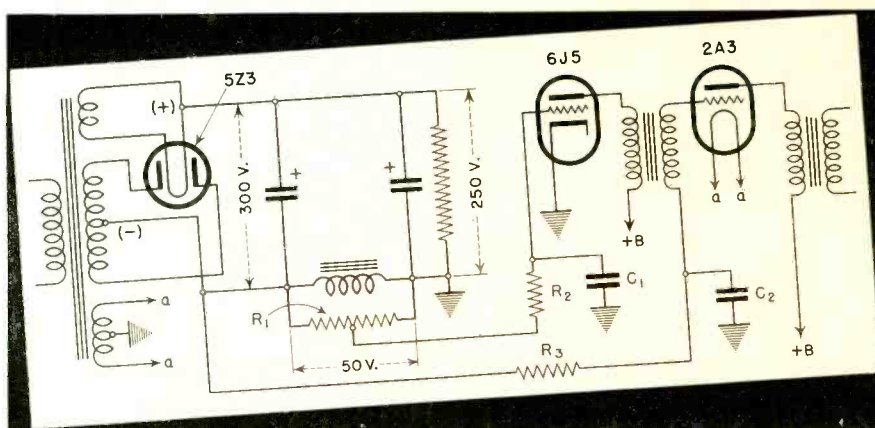

Fig. 3. Bias from negative leg of power supply.

zero. For tube 2, however, the grid return must travel through the filament of tube 1 to reach its negative terminal; consequently, the effective grid bias is equal to the filament voltage of the tube 1, or 2 volts. For tube 3, the grid return passes through the filaments of both tubes 1 and 2; the grid bias is therefore the sum of the filament voltages, or 4 volts. This method of biasing the grids is frequently utilized in hearing aids.

CATHODE BIAS

Most receivers are line-operated. And, in such receivers, the most familiar method of obtaining grid bias is by the use of a cathode resistor, as shown in Fig. 2-A. Actually, what happens in this circuit is that the cathode is rendered positive with respect to the grid—which is equivalent to saying that the grid is made negative with respect to the cathode. Just how this takes place is pretty generally understood, but for the benefit of some of our more recent associates, let us briefly review the subject.

When a positive voltage is applied to the plate of the tube, electron current flows from the cathode to the plate; thence back to the cathode through the external circuit. In Fig. 2-A, the cathode resistor R is part of the external circuit through which this current must flow. And, by Ohm's law, when current flows through a resistance, a voltage E equal to IR is developed, in which I is the current in amperes and R is the resistance in ohms. Thus, in this circuit of Fig. 2-A, if we assume the resistance to be 300 ohms and the current to be 10 milliamperes (.010 ampere), the voltage drop becomes

$300 \times .010$ or 3 volts. This is a good thing to know in cases where cathode-resistor values cannot be determined. By consulting a tube manual and noting the rated plate current (if the tube is a triode) the cathode resistor value required may be calculated.

For tubes with screens and other grids drawing current, we must add their currents to the plate current in order to determine the resistor value required for the cathode. In Fig. 2-B, where a pentode is shown, the screen current also must pass through R to return to the cathode. If this were a type 47 tube, for instance, in which the plate current should be 31 ma (.031 amp.) and the screen current 6 ma (.006 amp.) when the plate and screen voltages are 250 and the grid bias 16.5 volts, we can figure the value of cathode resistor, R , required as follows:

$$R = \frac{E}{I} = \frac{16.5}{.031 + .006} = \frac{16.5}{.037} = 446 \text{ ohms}$$

Actually, as you will note, the tube manuals specify 450 ohms. The value is not particularly critical.

One point should be emphasized—don't attempt to apply these formulas to resistance-coupled stages. When there is a high resistance in the plate circuit, the actual plate voltage is not the same as the plate supply value, due to the drop in the plate resistor. Therefore, we cannot take the rated plate current at a given operating voltage as a means of calculating the bias resistor needed. The required value, in the case of high- μ triodes, may be obtained by using load lines and characteristic curves, but since most tube manuals give tabulated values for many sets of conditions, there is no need to go to this

trouble. For pentodes in resistance-coupled stages, the application of load lines is very complex, but, again, the tube manuals furnish ample data for suitable values.

POWER-SUPPLY BIAS

When the bias voltages are obtained from the power supply, the principal factors are no longer the plate current of the amplifier tube, but the total current of all the tubes, and of the bleeder resistor in the power supply. In determining the polarities and return points for the various tube elements, remember that the cathode of the rectifier is always the most positive point and the plate, or plates (of a full-wave rectifier) are the most negative.

This is shown in Fig. 3. The total power-supply voltage is 300, of which 250 volts is employed as the plate supply and the balance for grid biasing. Note that the choke is placed in the negative leg of the power supply. The most negative points are, as stated above, the plates of the rectifier. The center tap of the high voltage winding of the power transformer is at substantially the same negative potential as the rectifier plates, since the d-c resistance of the winding is very low and consequently there is very little voltage drop in the winding. When the cathodes of the amplifier tubes and B minus are joined—both are grounded in the diagram—the full bias of 50 volts is applied to the type 45 tube grid. While this bias voltage must pass through the resistance-capacity filter R3-C2, since the grid draws no current there is no voltage drop across R3 and

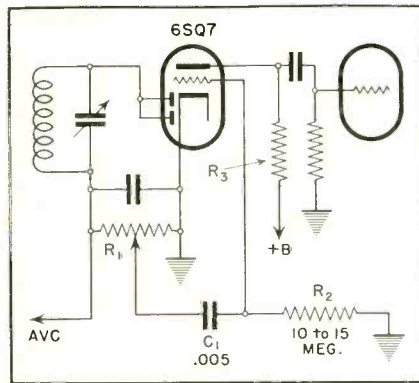

Fig. 4. Contact-potential bias.

therefore no loss in voltage. The 6J5 requires less bias; consequently, a tapped voltage divider R1 is shunted across the filter choke to obtain the proper voltage. In some receivers the choke itself is tapped. If it becomes necessary to replace such a choke, and an exact replacement is not obtainable, it is well to remember that a voltage divider, such as R1, can be used to accomplish the purpose when a standard choke of the same d-c resistance as the tapped choke is employed. The bias voltage is filtered through R2-C1 before being applied to the 6J5 grid.

In some receivers, the C bias is grounded instead of the B minus. In such cases, remember that the bias is always figured with reference to the cathode, not to ground. If the cathode is connected to some point along the power-supply bleeder which is positive with respect to the point to which the grid is returned, then the grid bias will always be negative, regardless of the position of the ground. In some circuits, in fact, the B plus is

grounded; for example, in cathode-ray oscillographs. The cathode is then highly negative with respect to ground, and to the plate. But this is equivalent to saying that the plate is positive with respect to the cathode, so the position of the ground makes no difference.

CONTACT BIAS

Naturally, there is a constant search going on for simpler, less expensive methods of making receivers. And the grid-bias problem is one which has been under scrutiny for quite some time. As a result of this study, a method known as "contact potential" biasing has been evolved, as illustrated in Fig. 4. In this method, the need for a tap on the power supply, or a cathode resistor with an associated bypass condenser, has been eliminated by taking advantage of the small negative voltage which results from grid current through a high value of grid resistor when the grid and cathode return to the same point. This grid current results from the bombardment of the grid by electrons when there is no applied negative voltage to repel the electrons, and is termed "contact potential." Actually, true contact potential also includes current due to gas and other spurious effects, but the term has been conveniently limited to the electronic bombardment in this reference.

In operation, when a signal voltage is applied, the grid current flow is increased over the positive half cycle of the signal and reduced over the negative half cycle. Therefore a variable loading effect on the signal source results. In order to minimize this effect, the grid-

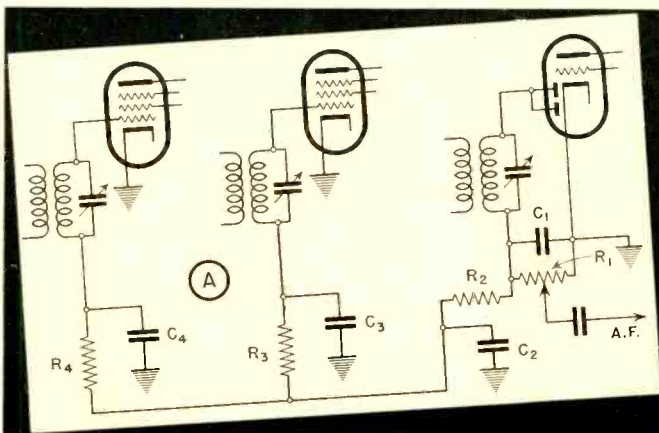

Fig. 5-A. Bias by means of diode contact potential.

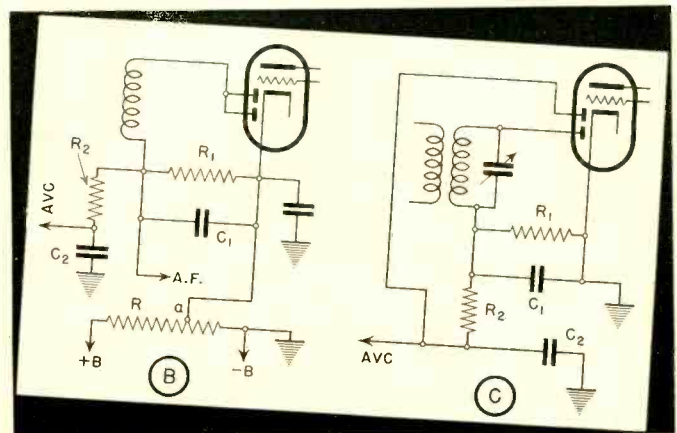

Fig. 5-B & C. Variations of diode contact potential.

CIRCUIT COURT

MIDGET PHONOGRAPH

WHEN IT COMES to getting a great deal out of a little, Silvertone takes the cake with their Model 5812 Electric Phonograph, the circuit of which is shown in Fig. 1.

The unit is complete in all respects, with its rim-driven a-c phono motor, crystal pickup, permanent magnet dynamic speaker and power output tube.

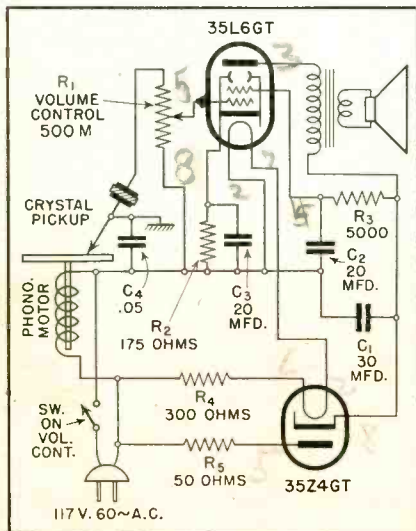

Fig. 1. Midget phonograph circuit.

The simplicity is derived from the fact that the average crystal pickup has an output in the vicinity of 3 volts and the 35L6GT beam-power tube a transconductance of

5800 micromhos. Since the 35L6GT requires very little driving voltage, the pickup is able to directly swing the tube to its full output of 1.5 watts.

The circuit is conventional in other respects—the heaters of the 35L6GT and the 35Z4GT half-wave rectifier being in series with the line and the voltage-dropping resistor R4. The screen supply filter is composed of the electrolytics C1-C2 and the resistor R3.

A.C.-BATTERY PHONO

PROVISIONS ARE made in the Silvertone Models 8929, 8930 and 8950 portable 30-watt high-gain amplifiers for operating the unit from either a 110-volt, 60-cycle line or a 6-volt storage battery—including the phono motor. The arrangement is shown in Fig. 2.

When the a-c adaptor plug A is in socket C, winding 1 of the power transformer is connected across the line and serves as the primary. Winding 2 supplies the tube heaters.

When the storage-battery adaptor plug B is in socket C, the heavy-duty vibrator V is connected to the storage battery. In this instance, winding 2 of the power transformer serves as a low-voltage primary across the vibrator output. The vibrator converts the d.c. into a 60-cycle pulsating current which appears as 110 volts

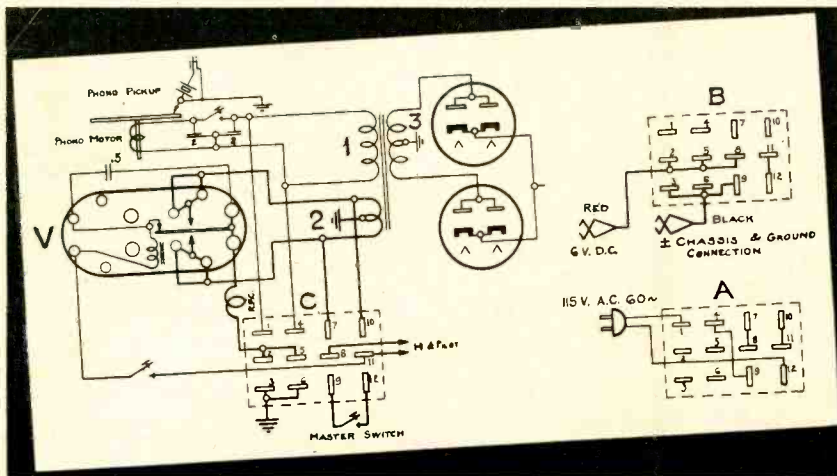

Fig. 2. An ac-battery-operated phono amplifier.

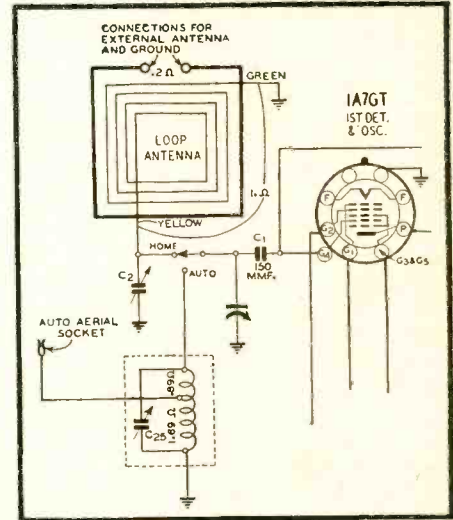

Fig. 3. Portable with plug-in auto antenna coil.

a.c. across winding 1, for the phono motor, and high-voltage a.c. across winding 3.

In order to conserve battery current, a stand-by switch, S, is placed in the vibrator lead. The tube heaters remain on, and plate current is applied, when required by closing switch S.

FOUR-WAY PORTABLE

A SWITCH IS provided on the new Wards Airline Model 14WG-680A ac-dc-battery portable so that it may be used still another way—as an auto-radio.

When used as an auto set, the tubes are operated from the dry-cell batteries. A switch on the side of the case permits the disconnection of the loop antenna and the connection into circuit of a special plug-in antenna coil, as shown in Fig. 3.

An accessory kit consisting of a whip aerial, floor plate, distributor suppressor, and the plug-in antenna coil, can be purchased separately for making the adaptation complete.

DOUBLE-UP CIRCUIT

SIMPLIFICATION of circuit design is to be found in Wards Airline Model 04BR-615A Radio-Phonograph-Recorder. Instead of employing a separate tube as the mike amplifier, the second i-f tube

is made to double up, as shown in Fig. 4.

When in use, the mike is shunted across resistor R8 in the grid circuit of the 6SJ7 second i-f tube. Appearing in the plate circuit of the same tube is the primary of the second i-f transformer and, in addition, the load resistor R11 and decoupling resistor R12. Also the audio coupling condenser C19 which connects from the plate end of R11 to one of the contacts on the 2nd section of switch S2.

Following from left to right the progressive positions of the two sections of switch S2, the 1st section connects the plate of the 6SK7 i-f tube to B plus; the 2nd section connects the diode output to the volume control. This is the position for radio operation.

The second position of these switch sections does not alter the circuit, but a 3rd section of the switch, not shown, connects the output to the cutter for off-the-air recording.

In the third position, the 1st section of S2 removes voltage from the plate of the 6SK7 i-f tube; and the 2nd section of the switch connects the coupling condenser C19 to the volume control, at the same time disconnecting the diode output. In this mike-recording position, the 6SJ7 i-f tube functions as an a-f amplifier, the a-f voltage being developed across resistor R11.

In the fourth position of the switch, the plate of the 6SK7 remains disconnected (to prevent radio break-thru) and the crystal pickup is connected to the volume control for phonograph operation, the diode output remaining disconnected.

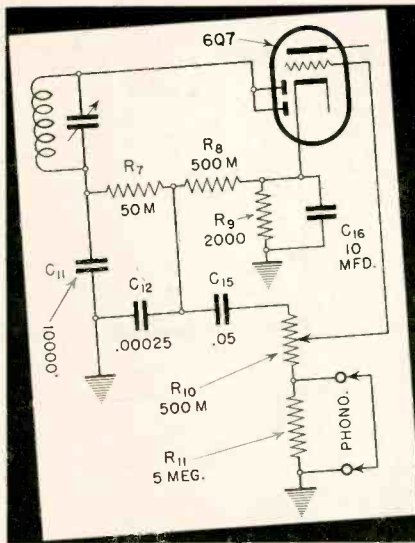

Fig. 5. Phono connection in series with volume control.

When the 6SJ7 is used as the i-f amplifier, resistor R11 has no effect other than to reduce plate voltage and serve as an additional decoupling filter in conjunction with C16. When the 6SJ7 is used as the mike amplifier, the primary of the i-f transformer in its plate circuit has a negligible effect on the audio frequencies involved.

PHONO CONNECTION

PHONOGRAPH tip jacks, with a jumper, are provided in the Wil-Cox-Gay Model A-79 receiver. The arrangement is shown in Fig. 5.

When the phonograph connection is not in use, the 5-meg pickup load resistor R11 is shorted by the jumper and the volume control R10 is directly grounded.

With the jumper removed and the pickup plugged in, the pickup voltage is developed across R11 in series with the volume control. Under these circumstances, the points of maximum radio and phonograph voltage appearing across the volume-control resistance will be diametrically opposed. Hence, if volume is controlled from the record player, placing the arm of the "radio" volume control nearest the low or grounded end will provide a minimum of radio signal and a maximum of phonograph signal as governed by the control of the record player.

Naturally, when the phonograph is in use, resistor R11 becomes a part of the a-f voltage divider in the diode output circuit, but with the arm of volume control R10 at minimum, the radio signal will be negligible.

CUTTER TRANSFORMER

IN THE radio-recorder Model 1291-RPA produced by Spartan, separate output transformers are used for the speaker and the cutter, the latter being plugged into a jack when it is desired to make recordings from radio or mike.

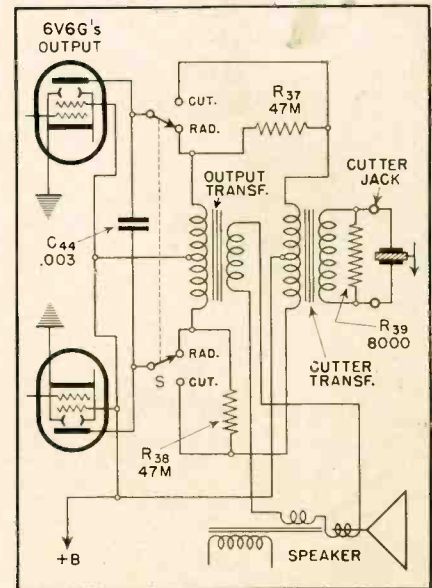

Fig. 6. Paralleled output and cutter transformers.

The portion of the circuit involved is shown in Fig. 6. It should be noted that the center tap of each transformer is connected to B plus.

With the dual switch S in the Radio position, plate voltage is supplied to the 6V6G beam-power tubes through the speaker transformer. With the switch in the Recording position, plate voltage

(Continued on page 34)

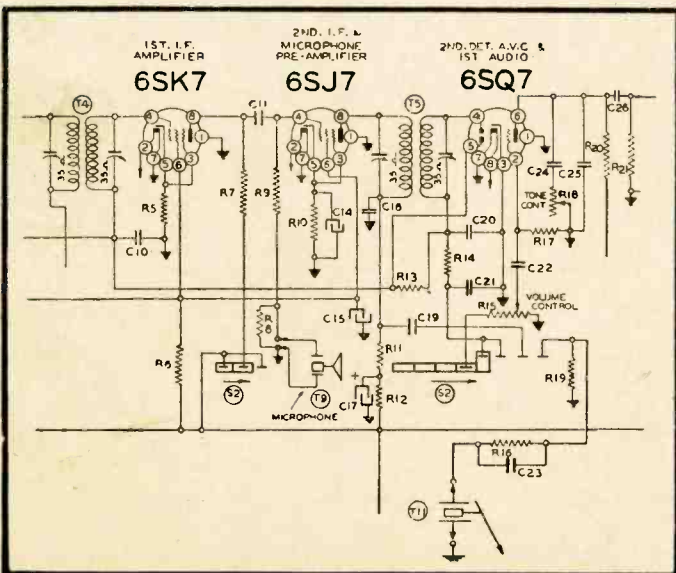
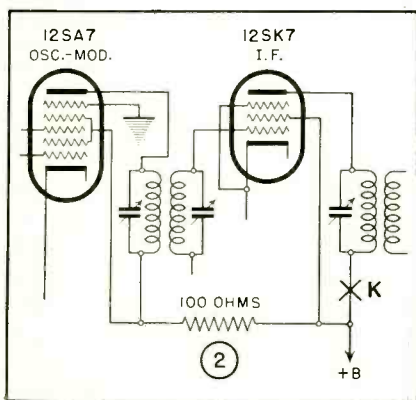

Fig. 4. Circuit using 6SJ7 as i-f or mike amplifier.

Shop Notes

FARNSWORTH BT-52,-53,-54,-55,-56 Circuit Change

In early production runs of these receivers, the 100-ohm resistor 2 was at point K in the primary circuit of the 2nd i-f



transformer. Better results may be had if this resistor is connected as shown in the accompanying diagram.

FARNSWORTH BK-77,-78 Circuit Changes

In late models of these receivers, the following changes were made:

The 8200-ohm resistor 6 supplying the screens of the r-f, converter and i-f tubes was changed to 12,000 ohms.

The 150,000-ohm resistor 13 in the negative leg of the power-supply circuit was changed to 220,000 ohms and grounded, rather than being connected to the midpoint of resistors 8 and 12.

The 10,000-ohm oscillator plate resistor 5 was changed to 22,000 ohms.

Electrolytic condensers 36 and 37 were changed from 350 v. and 250 v. rating, respectively, to 400 v. and 350 v. respectively.

RCA 6SF7 & 12SF7 TUBES

The 6SF7 is a multi-unit, single-ended, metal tube containing a remote cutoff pentode and a single diode detector. The tube is recommended for use as a combined i-f amplifier and detector. When so used in phono-radio combinations, the

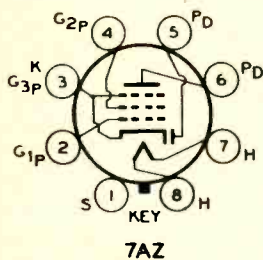

6SF7 minimizes the difficulty from play-through from the radio circuit. The 6SF7

may also be used as a resistance-coupled a-f amplifier and will give the same high gain and voltage output as similar pentodes.

The 12SF7 is identical with the 6SF7 except for its heater rating of 12.6 volts and 0.15 ampere.

Bottom view of the socket connections for both these tubes is shown in the accompanying sketch.

RCA 6SN7-GT TUBE

The 6SN7-GT is a single-ended, twin-triode amplifier having separate cathode terminals for each triode unit. It is recommended for use in resistance-coupled cir-

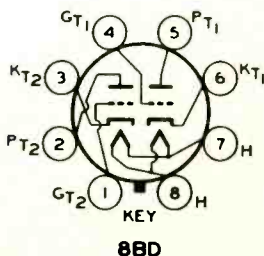

cuits as a voltage amplifier or phase inverter. In push-pull and phase-inverter applications it offers much greater flexibility in circuit design than do twin triodes having only a single cathode terminal.

Bottom view of socket connections are shown in the accompanying sketch.

RCA RP-152, RP-153, RP-155 Changes

The following changes have been made in these Record Changers:

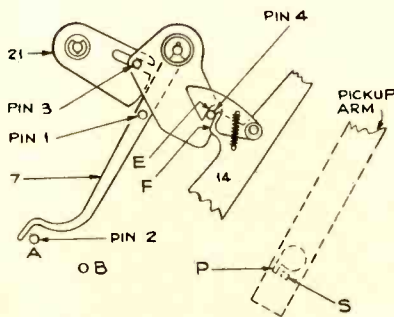

Removal of Trip Regulator Lever (Part 21).

Removal of Pin 1 on Trip Lever Friction Finger (Part 7).

Repositioning of Stop Pin 2 from position "A" to Position "B."

Removal of Pin 3. Since this pin does not interfere with the operation, it has been left in some mechanisms.

The Trip Regulator Lever was formerly used to prevent premature tripping due to a too early return of the Trip Lever Friction Finger at the end of each changing cycle. The same result is obtained by removing the Trip Regulator Lever and repositioning the Trip Finger Stop Pin as shown in the diagram.

Binding or Hesitation of Tone Arm

This may be due to the following causes:

(1) Small burr on edge "E." **Correction:** Carefully remove burr with a fine file until edge is entirely smooth.

(2) Binding of Pin 4 between edges "E" and "F." **Correction:** File off edge "F" with a fine file to give just enough clearance for smooth operation.

(3) Too far an outward swing of the Pickup Arm. This causes Pin 4 to be caught in the upper curved portion of edge "F." **Correction:** On some models the Pickup Arm Shaft can be rotated by loosening the nut under the motor board. Rotate sufficiently to prevent Pin 4 from riding into curved portion mentioned, when Pickup Arm is in the outermost position.

On models where the Pickup Arm Shaft is positioned by a locating key, it is necessary to bend Stop Guide "S" on Pickup Arm towards Stop Ear "P" on Pickup Arm Shaft so that the condition mentioned in the above paragraph is obtained.

SILVERTONE MODEL 6306 Extended Range

The frequency range has been extended to cover 1600 kc. This requires that the oscillator trimmer C11 be peaked with the signal generator set to 1605 kc and the gang condenser fully open, instead of to 1520 kc as originally specified.

The range of push-button No. 5 has been changed from: 920-1570 kc to 950-1600 kc.

SILVERTONE MODEL 6490-B Component Change

Later production of 101.613 and all 101-613-A have a choke (Part No. 1013040-442) in place of the 4700-ohm resistor R7 shown in the original circuit.

WILCOX-GAY A-89,-91,-92,-93,-94 Shunt Pickup Resistor

Beginning with serial No. 621520, all chassis used in dual-speed Recordio models, resistor R36 connected in shunt with the phonograph pickup input circuit, has a value of 2 megohms in place of 500,000 ohms as indicated in the original schematic diagram.

The resistance value of R36 governs the amount of bass response that may be obtained in playing phonograph records, without encountering "rumble" or "microphonism" due to cabinet resonance. Increasing the resistance value increases the bass response, and vice versa.

By use of the 2 megohm resistance value, the degree of low-frequency response is adjusted to a safe margin from the borderline of microphonism.

Should it be desired to increase the bass response of phonograph record reproduction in dual-speed Recordio models bearing serial numbers lower than indicated above, the highest resistance value, not to exceed 2 megohms, should be used in circuit position R36, that affords record reproduction at full volume entirely free from microphonism.

FM-AM TUNER

(Continued from page 7)

taurants and the like, there is an obvious advantage in providing the highest possible quality and naturalness of reproduction. While high tonal fidelity has been the most strongly emphasized feature of f.m., it is the feeling of many experts that the advantage of f.m. over really good a-m reproduction is relatively negligible in this respect. There are good a-m tuners capable of reasonably flat response over a range of 40 to 7500 cycles. Whether the public can fully appreciate even this range is an oft-debated question.

But the freedom from noise and far wider dynamic volume range of f.m. are features which add tremendously to the effectiveness and naturalness of radio reproduction. It is difficult to convey to the listener the presence of live music when the normal volume variation range of the symphony orchestra is squeezed down to the relatively compact modulation limitations imposed on the a-m broadcast station by law and technical considerations. Or when reproduction is being continually punctuated by the crackle and crash of natural or man-made static.

Thus it is obvious that an f-m tuner becomes a logical replacement for many a-m tuners now in use with sound systems, and that f-m provides a new selling point favoring installations where they do not now exist.

So far as the f-m tuner is concerned it is believed that for sound-system applications provision should also be included for a-m reception. This is particularly true during the "incubation" period while f-m stations are relatively few. In this way the best of a-m and all f-m reception is made available.

FM-AM TUNER

The accompanying illustrations show a tuner which offers, both physically and electrically, special advantages for sound-system applications. In the first place, it takes the form of a rack and panel job. This makes it particularly appropriate for use in rack-assembled school, institutional and hotel systems; either as a replacement of an additional unit of the assembly. It also makes this unit simple to add to any existing system because it lends itself readily to out-of-the-way wall mounting, or to installa-

THE BIG NEWS IN PORTABLE RADIO IS THIS LITTLE BATTERY



"Eveready" "Mini-Max" Radio "B" Battery No. 482 outsells all other portable batteries combined. Reason? It fits more than 90% of the 2,000,000 portable sets now in use. It lasts almost twice as long as ordinary batteries of equal size. It costs no more than ordinary portable battery. Ask your distributor about this profit-maker now!

FREE PREMIUM OFFER!
ASK YOUR DISTRIBUTOR ABOUT IT!

Here's the battery for "personal" or "camera-type" radios!



"Personal" or "camera-type" sets were designed around "Eveready" "Mini-Max" Radio "B" Battery No. 467. It packs 67½ volts in a space 3⅝" x 2¼" x 1⅞". Folks in your neighborhood will ask you if you have it. Order now!

"EVEREADY"
"MINI-MAX"
RADIO "B" BATTERIES

NATIONAL CARBON COMPANY, INC.

Unit of Union Carbide and Carbon Corporation



The words "Eveready" and "Mini-Max" are registered trade-marks of National Carbon Company, Inc.

FREE! Replacement Guide for portable receivers! Tells the proper batteries for portable sets. Accurate! Up to the minute! Write Dept. D, National Carbon Company, Inc., P.O. Box 635, New York, N. Y.

NEW PRODUCTS

OF THE MONTH

SHURE

Communications Mike—Model 730-S "Uni-plex" cardioid crystal microphone is dead at the rear. Cuts down room noise pick-



up, eliminates echoes, cleans up voice transmission, makes break-in phone easy. Built-in r-f filter protects against burnouts. Output level: 33 db below 1 volt for 10 bar speech signal. Uses moisture-proofed Grafoil Bimorph crystal. Swivel head, Built-in cable connector. Satin chrome finish. Standard $\frac{5}{8}$ "-27 thread. Diameter $3\frac{1}{8}$ ", depth $3\frac{3}{8}$ ". Complete with 7-foot shielded cable. By Shure Brothers, 225 W. Huron St., Chicago.

WALSCO

Dial Belt—The "Unibelt" is adjustable to fit any dial and comes open, so that the belt may be installed without taking the dial mechanism apart. A zipper-like fastening gives instant, durable connection.

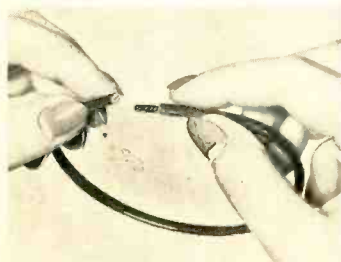

The core of the Unibelt is made of tempered, highly flexible steel which eliminates stretching. By Walter L. Schott Co., Los Angeles.

IRC

V-C Kit—Available for the rapid and convenient handling of Moving-Day backlog business is the Master Radiotrician's Volume Control Kit composed of cabinet packed with 18 Type D All-Purpose Controls with 6 switches and 5 extra Tap-in Shafts of special design—an assortment capable of handling from 60% to 75% of all replacements. Controls unsuited for general work can be exchanged through local jobber. By International Resistance Co., 401 N. Broad St., Philadelphia.

VERTROD

Rod Aerials—Three new types are available: Model 100 for the range of 500 to 1700 kc; Model 103 for communications work, with a range of 500 kc. to 30 mc; and Model 104, for f-m and a-m receivers, with two ranges, one from 500 to 1700 kc and the other 40 to 60 mc. By Vertrod Mfg. Co., 132 Nassau St., New York, N. Y.

RADIOTECHNIC

Tube Tester—Model 120, in counter or portable type, has new permutation switching system providing proper voltages on any tube pin and capable of accommodating future tubes without additional wiring. Filament voltage range from 1 to 117. All standard 4-5-6-7 sockets, octal, loktal, Hy-

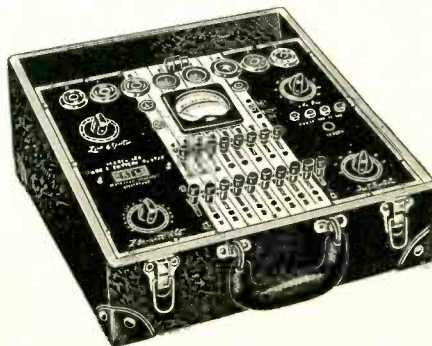

tron, Raytheon CK, and two spare positions. Has triple output test, hot short test, and battery test with voltmeter ranges of 0-10-100-1000. Illuminated dial on 3" meter. Tube chart is mounted in slide drawer in counter model; in cover of portable model. By The Radiotronic Laboratory, 1328 Sherman Ave., Chicago.

DeWALD

"Jewel" Radio—Model 562, 5-tube ac-dc superhet in colored Catalin-molded cabinet. Has tilt-top slide-rule dial, and tunes from 170 to 555 meters. Beam-power output, built-in loop, avc, dynamic speaker. Available in alabaster with ivory, red or



blue trim; onyx with ivory trim, and maroon with ivory trim. By DeWald Radio Mfg. Corp., 436 Lafayette St., New York, N. Y.

CINAUDAGRAPH

Dual Speaker—Cin-axial Dual Speaker System, incorporating a 12" woofer, a 5"

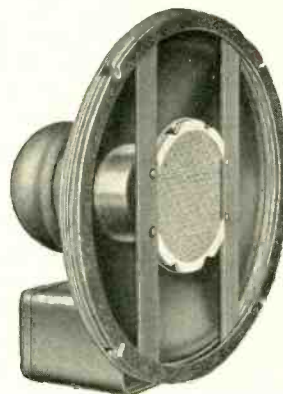

tweeter, and complete cross-over network. Substantially flat from 30 to 12,000 cycles. Useful range considerably in excess of 12,000 cycles. Expressly designed for use in high-fidelity phonograph equipment and for f-m reproduction. By Cinaudagraph Speakers, Inc., 2 Selleck St., Stamford, Conn.

BETTS & BETTS

Delay-Switch—Time delay switch to provide predetermined time delay in electrical control. Designed for use with magnetic relays. Provided with two heater terminals and two contact terminals. Adjustable

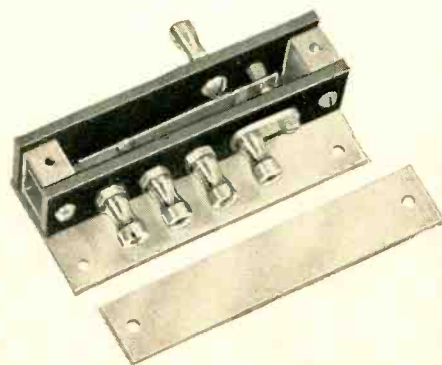

within the time limits of one second to five minutes. Available in immediately or not immediately recycling types, normally open or normally closed. By Betts & Betts Corp., New York, N. Y.

THORDARSON

Mobile Amplifier—Model T-30W12 weighs only 20 lbs and has 12-watt output with less than 5% distortion. Operates from 6-volt storage battery. Rotary selector switch provides several output impedances. Standby switch included. Complete unit measures $13\frac{1}{2}$ " x $7\frac{1}{2}$ " x $7\frac{1}{4}$ ". By Thordarson Electric Mfg. Co., 500 W. Huron St., Chicago.

tion in an existing console, bookcase or other furniture. Or, if none of these is considered essential, it can be used as a simple table model to be placed on top of existing amplifier equipment or wherever convenient.

The model shown is the Hallcrafters S-31 tuner. It provides only for broadcast reception, including the a-m range of 550 to 1600 kc and the f-m range of 40 to 51 mc. Each of these ranges is completely calibrated on the large slide-rule dial. Accurate tuning is insured through inclusion of a tuning meter which functions as a standard "S" meter for a-m reception and as an accurate carrier-centering indicator when tuning f-m stations. This latter is particularly important because it is only when the receiver is precisely tuned to the center of the f-m carrier that best fidelity and maximum noise reduction are obtained.

A single tuning "wheel" performs the entire tuning operation. In addition to this there are the conventional a-f gain and tone controls, an a.m./f.m. switch, and a radio/phono switch which also includes the a-c off position. A head-phone jack on the front panel provides for monitoring.

Each clearly labelled, these controls offer no difficulties for the non-technical operator. In fact, they simplify control of a centralized system that is employed for both radio and phono reproduction inasmuch as both can be directly controlled at the tuner. This is made possible by provision of phono input terminals at the rear of the tuner to permit the pickup to work through the single audio stage of the tuner. It's a-f gain control therefore serves for both phono and radio inputs.

THE CIRCUIT

The circuit utilizes 9 tubes including the 80 rectifier. Of these the 6SK7 preamplifier, 6SA7 converter, and the triode section of the 6SR7 output tube are common to both f-m and a-m channels. In addition, the f-m channel includes an 1852 (6AC7) first i.f. and 1853 (6AB7) second i.f., both working at 4.3 mc; a 6SJ7 limiter and 6H6 discriminator. The a-m channel includes a 6SK7 i-f amplifier operating at 455 kc and the diode section of the 6SR7 output tube. The single a-m i-f stage includes a band-pass input circuit with four tuned elements. These, with its double-tuned output transformer, provide six tuned i-f circuits in all

1942? FACTS About Next Year's Models!

FACT 1. It takes a long time to build a really GOOD test instrument—to get the "bugs" out—to prove, and improve, its performance and reliability. Then—when it's REALLY good—why change?

FACT 2. Today's SUPREME Instruments are as modern, as accurate, as dependable as test equipment can be built.

FACT 3. That is because SUPREME believes in, and practices, a policy of continuous improvement instead of just "putting a new coat of paint on an old chassis."

FACT 4. A new SUPREME model is never announced until progress in radio has developed a definite need for such an instrument.

FACT 5. Therefore, SUPREME will announce NO "new" models at the June radio show. Which proves that SUPREME Engineers know their business—that they know, and are guided by, YOUR requirements.

FACT 6. SUPREME Test Equipment for 1942 will be as it is now, your best buy, and "SUPREME BY COMPARISON!"

Write for SUPREME'S current catalog. It pictures and describes the instruments your Jobber has in stock NOW—for 1942. Due to present conditions, prices and prompt delivery guaranteed only until June 1st.



Still time to get your new SUPREME Book explaining a new servicing procedure that makes an ailing radio talk to you like a patient talks to his doctor. Only 35c to cover cost of printing and mailing.

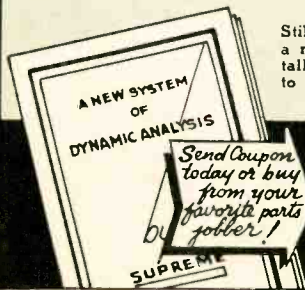

SUPREME Instruments Corp., Dept. SD2 Greenwood, Miss. Gentlemen: I enclose 35c. Please send me your new book referred to above.

NAME _____
ADDRESS _____
CITY _____ STATE _____

and combine the wide-band, steep-skirted characteristics required for good fidelity with ample selectivity.

Antenna terminals provide a choice of doublet or standard "L" type antennas. The output of the tuner is 130 milliwatts and is available at two pairs of output terminals to match either 500- or 5000-ohm lines. This output is purposely made ample to operate through the relatively low-gain audio systems of good radio receivers and is, of course, more than ample for use with any standard amplifier system.

Characteristics of f-m operation include i-f band-width of 150 kc at 6 db down from resonance; full limiting action on signals above 35-45 microvolts; audio amplifier flat to less than 2 db from 30 to 10,000 cycles; and down only 4 db at 15,000 cycles, image ratio varying from 90 to 140. In broadcast-band operation, average sensitivity is 20 microvolts at 6 milliwatts output; the i-f band-width 14 kc at 6 db down from resonance. Overall response is flat within 7 db from 30 to 5000 cycles.

(Continued on page 27)

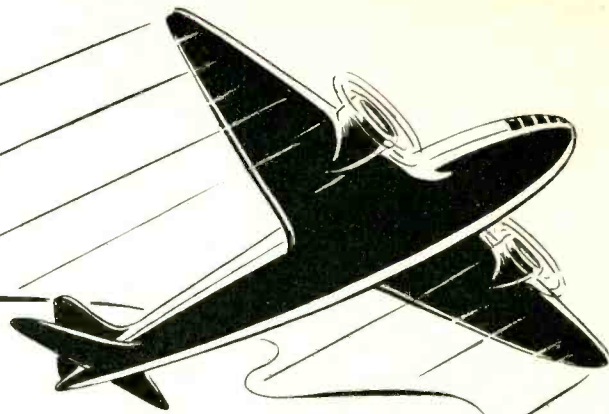

Moving...

WITH THE "SPIRIT OF YOUTH"

RADIO SERVICE-DEALER is young: just entering its second year. We're proud of our youth, proud that we haven't gotten into a rut or old-fashioned. We know it's our duty to our readers to maintain a staff out in the field working closely with service-dealers, soundmen and jobbers—making their problems our problems. No other serviceman's magazine has such a staff. We aren't satisfied with RSD. We'll continually strive to keep our readers best informed technically and otherwise. The radio servicing profession is becoming more complex as days pass by. The nation's best radio service-dealers subscribe to RSD, for we accept subs from only the best men in the profession. Join the growing ranks (now over 5,000 paid) and send us your subscription today. Use—and urge your associates to use—the coupon below.



This distinctive six-inch decalcomania lithographed in four colors (red, white, blue and gold) which will help your business, available FREE to all subscribers classified as Independent Radio Service-dealers on request.

-----TEAR OUT AND MAIL TODAY-----

RADIO SERVICE-DEALER

11 West 42nd Street, New York City, N. Y.

Sirs: Here is my check (or money order) for \$..... Enter my subscription order to RSD for the next issues. (12 issues cost \$2.—24 issues cost \$3.) Canadian and Foreign subscriptions are \$3 annually. The information given below is accurate. If my subscription is rejected I expect an immediate refund in full.

Name (print carefully)

ADDRESS FIRM NAME Est. 19.....

CITY STATE YOUR POSITION

Please check whether firm is

- An independent servicing organization
- An independent service-dealer (engaged primarily in service work)
- A service-dealer (does servicing, but is primarily interested in retailing)
- Selling, renting or servicing Sound Equipment
- Jobber Any other classification
- Manufacturer (State it)

We stock the following checked items:

- TUBES
- PARTS
- RECEIVERS
- BATTERIES, etc.
- SOUND EQUIP.
- ELEC. APP'L'S.

We own the following instruments:

- V-T Voltmeter
- Tube Checker
- Analyzer
- Oscillator
- Signal Generator
- Volt-Ohm Meter
- Others
- MANUALS

I belong to a serviceman's organization Yes No

6

SPECIAL AMPLIFIER

A special high-fidelity amplifier, matching the tuner in size and finish, is the Hallicrafters Model S-31A shown with it on a rack in one of the accompanying illustrations. While designed primarily for use with this tuner, the amplifier includes provisions for all-around sound work. Briefly, its specifications include: 6 tubes terminating in a pair of 6L6's with phase inversion and inverse feedback for full 25-watt undistorted output; response characteristic flat within 1 db from 40 to 15,000 cycles; output terminals for 500, 8 and 4 ohms; variable bass control providing a variation range (from normal) of 5 db down to 10 db up; treble control to permit variation from 10 db above to 10 db below normal; overall gain of 90 db from microphone input, 50 db from phono and radio inputs; separate phono and radio terminals with dual fading control; screw-plug microphone input connections and separate microphone gain control; fuse replaceable from the outside rear of cabinet; pilot light, etc.

Equipment such as that described not only satisfies the requirements of centralized sound systems, but is likewise appropriate for installation in many homes where good existing equipment needs only a tuner to provide the enjoyment of f-m broadcasts. This is particularly true in homes that boast built-in radio installations, or where it would be desirable to house the additional tuner in a bookcase or other existing furniture. There are millions of dollars worth of high-fidelity receivers now in use in homes—receivers with audio and speaker systems suitable for f-m reproduction. Owners of many of these do not constitute prospects for complete f-m receiver equipment, but are mighty good prospects for an accessory tuner, especially if it is of a type which lends itself to out-of-the-way placement rather than adding another piece of furniture in the living room.

RCA V-101

(Continued from page 19)

section of this switch turns on the receiver when the knob is moved one notch forward from the position shown in the diagram. Moving the contact segment forward two more notches, to contact 5, turns on the phonograph motor.

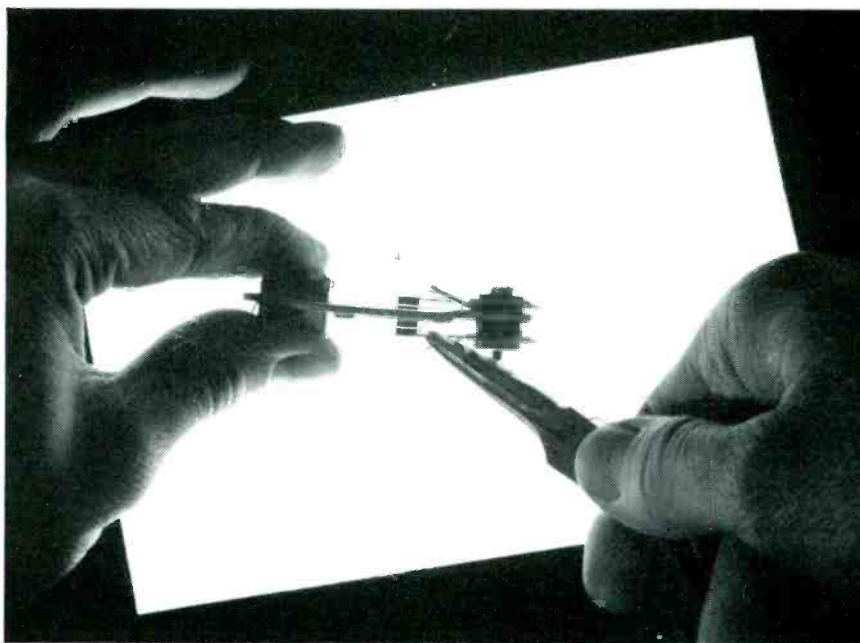

Heart Trouble Avoided by This Utah Operation

HANDS as skilled as any surgeon's perform this delicate operation in the Utah factory. This precision adjustment of the contact points in Utah Vibrators is responsible for their long life, correct electrical balance, current output and freedom from noise.

Because Utah contact points are adjusted to a specified clearance, with a variation of less than .0005 in., they eliminate the causes of failure so frequently found in ordinary vibrators. Pitted or locked points, unsatisfactory performance and short life are avoided.

Only high quality materials conforming to rigid standards are used in the

manufacture of Utah Vibrators. The points, for example, are made of the best grade Tungsten, fully capable of standing up under the terrific punishment to which they will be subjected.

Write for information about the complete line of high-value, dependable Utah Vibrators. Utah Radio Products Company, 836 Orleans Street, Chicago, Illinois. Canadian Office: 560 King Street West, Toronto. In Argentine: Ucoa Radio Products Co., SRL Buenos Aires, Cable Address: Uta-radio, Chicago.



VIBRATORS

SPEAKERS • TRANSFORMERS • UTAH-CARTER PARTS

The rear section of the switch has two contact segments; one for phono-radio and the other for tone control. When the shaded segment contacts 8 and 10, the diode output is connected to the volume control. Moving the switch two notches forward connects contacts 10 and 11 and opens 8. In this position, the diode output is disconnected from the volume control and the pickup connected.

The intermediate positions of switch S2 provide tone control in both the radio and phono positions.

The black segment has two fingers properly spaced so that the .0025-mfd condenser C15 is grounded at one of the radio and one of the phono switch positions. Since this condenser is tied to the plate of the 6SQ7, the highs are attenuated when the condenser is grounded.

The actual operating positions of this switch are shown in Fig. 1.

ALIGNMENT

With the gang in full mesh, move the dial pointer to the reference mark at the left-hand end of

the dial backing plate.

Place a flat 6-inch ruler on the dial backing plate so the left end of ruler is at the reference mark at left end of backing plate. Temporarily fasten the ruler with Scotch tape to the backing plate.

Refer to calibration scale in Fig. 1. This is a reduced reproduction of the dial with an inch-scale drawn at the bottom. To find the correct pointer position in inches for any desired frequency, draw a vertical line through this frequency on the calibration scale.

Connect high side of test oscillator to 6SK7 grid through 200 mmfd, tune test oscillator to 455 kc, turn radio dial to quiet point between 550-750 kc, and adjust L7 and L8 on 2nd i-f transformer (see Fig. 1) for maximum output.

With everything as is, connect test oscillator to grid of 6SA7 through same condenser and adjust L5 and L6.

Proceed by connecting test oscillator to a radiation loop, tuning test oscillator and receiver to 1500 kc and adjusting C25 and C23 for maximum.

Wind up by setting oscillator and receiver to 600 kc and rocking in L4 for maximum output.

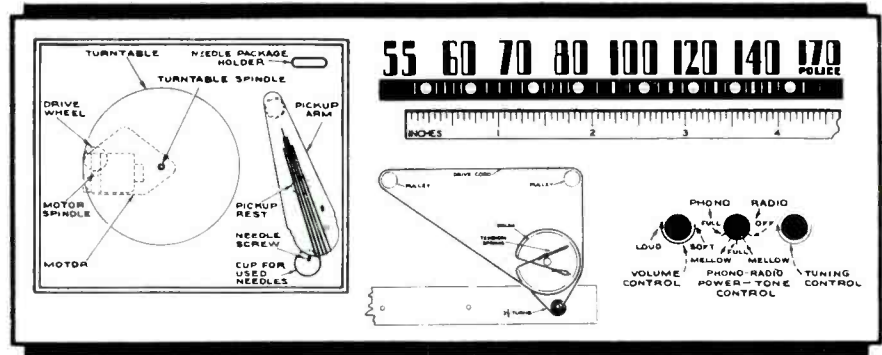

Fig. 1. Motorboard, calibration, control and dial-cord details, RCA Model V-101.

LEAD DRESS

Dress the 10-meg resistor and .01-mfd condenser on the 6SQ7 grid as far away from heater and power leads and the .25-mfd condenser C12 as possible. The 10-meg resistor leads must also be very short and dressed against the grid, away from the 2nd i-f transformer.

Dress the yellow lead between 2nd i-f transformer and the switch as far away as possible from the 10-meg resistor and .01-mfd condenser on 6SQ7 grid.

Dress the bus between 6SK7

plate and 2nd i-f transformer toward front apron and as far away from the 6SQ7 as possible.

Dress the red lead between the rectifier and the switch against the corner of the chassis and front apron.

Dress the green 6SA7 control-grid lead close to chassis and as far away from the blue plate lead as possible; the latter also down against the chassis and as short as possible.

The brown heater leads, black, and brown pilot light leads, and all power and output leads must clear resistors and condenser on the 2nd i-f transformer by at least $\frac{3}{4}$ ". Especially the heater lead between the 25L6GT and 6SK7, which must be dressed against the rear apron.

RADIO OUTLETS

(Continued from page 14)

mitter, must be met by providing heavier insulation between windings of the antenna transformer. In the earliest installations some antenna transformers promptly broke down from this cause. Fifth, the radio transmission line must be so snaked through bulkheads and from deck to deck as to minimize the runs from outlet to outlet.

Taking care of these various factors, we have evolved the marine multicoupler-antenna system already installed or being installed on over seventy cargo boats and tankers. Such radio wiring is standard equipment for the Maritime Commission cargo ships of the C₁, C₂ and C₃ classes, as well as on oil tankers.

The system starts with the aerial serving up to twenty-one outlets. Of the doublet type, the aerial comprises two lengths of wire, each 30 to 50 feet long, joined at the middle by a group of insulators, as shown in the accompanying sketch. The download con-

"HOMER'S BACK"

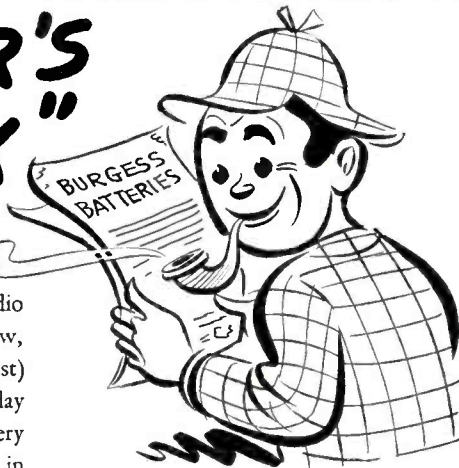

Since losing his job in Bud's Radio Shop, our hero, Homer G. Snoopshaw, B. R. S. (Battery Replacement Specialist) really has been up against it—but today he received a letter from Burgess Battery Company offering him a position in Burgess' own Replacement Laboratory—the very spot where the famous Replacement Guide is prepared! What a break—for Homer! And for Burgess!

Homer starts work next Monday, and his position will be "Advisor Extraordinary to Radio Dealers Everywhere." If you are one of the few dealers who don't have a copy of the latest Burgess Replacement Guide, see your distributor or write to Homer, c/o Burgess Battery Company, Freeport, Ill., and you'll get one right away. Answers over 520 portable replacement problems.

HAVE YOU SEEN

the New Burgess XX45? Made especially for the new "Personal" Radios— weighs less than 12 oz., rated at 67½ volts, and sells for only \$2.25. Equal in service to any of comparable size.



If you are not fully informed on the Burgess line, you'll be doing yourself a favor if you write in for full information—We'd be glad to hear from you.

BURGESS BATTERY CO.
FREEPORT, ILLINOIS

BURGESS
The Complete Replacement Line

nects at this center point, and goes to the antenna transformer placed in a metal box mounted on a bulkhead, stanchion or mast, which box also includes the lightning arrester. From the antenna transformer the radio transmission line goes to the couplers and outlets being served, the ground shield of this line being grounded at its free end.

The aerial follows standard marine radio practice, using stranded 7/18 phosphor-bronze wire. The joints are tightly spliced, soldered, and wrapped with tape. For the download, a twisted-pair heavily-insulated and protected cable is used to withstand years of severe service.

The radio transmission line concentric dual-conductor cable must offer the lowest dielectric loss, or not exceeding 2 decibels per 100 feet at 15 megacycles (20 meters). Also, the characteristic impedance must come between 60 and 70 ohms. These requirements cannot be met with ordinary code insulated rubber wire. We have tested many kinds and brands of cable, and as a result have recommended two choices of concentric dual-conductor cables with rubber covering suitable for concealed wiring in conduit, and one with lead covering for exposed wiring.

The individual set couplers are wired in parallel with the radio transmission line. They are placed in suitable boxes provided with face plates and receptacles. Over 75% of present installations use the 4 x 4 inch standard outlet box with a face plate containing the radio receptacle and two standard Edison receptacles for ship's electric power. The radio receptacle takes a special plug connected with the antenna-ground terminals of the set.

AVERAGE REQUIREMENTS

Serving up to 21 outlets with each aerial, the usual cargo ship or tanker requires but a single aerial to take care of its radio entertainment needs. Some ships have two and even three such aerials. The Esso tanker Nashville for instance, has three aerials, the portside-aft aerial serving 13 outlets, the starboard-aft aerial 11, and the forward aerial 9. The accompanying sketches indicate typical aerial arrangements on tankers and Maritime Commission cargo ships.

With the aerial strung high above deck, well outside the noise zone created by the ship's electrical

equipment, and with a radio transmission line that cancels out inductive interference, the marine multi-coupler-antenna system provides good radio reception in both broadcast and short-wave bands. Certainly the aerial is far superior to that which the crew might put up for private radio purposes.

Outlets conveniently located permit radio reception in crew's quarters and in officers' staterooms. Working from blueprints of a ship either under construction or commissioned, our engineers

spot the outlets and then lay out the radio transmission lines or risers for minimum runs to and between outlets. The cable snakes its way from one compartment to another and from deck to deck, frequently zig-zagging about in a seemingly circuitous manner, yet checking for shortest runs and greatest operating efficiency. Due to the diversification encountered in marine architecture, almost every ship is a special layout job, but our engineers through the handling of dozens of layouts have become

Troubled with HAYWIRE Hook-up Jobs?

These Hook-up Wires are Approved —they're made by Belden

Characteristics at Room Temperature and Humidity

Feet	Insulation* Voltage	Resistance Megohms	Weight	Wire
1400	9.0			PUSH-BACK • DOUBLE BRAID • WAXED Solid—8830 Size 20—8866 Size 18 Stranded—8831 Size 20—8867 Size 18
6900	300			RUBBER PUSH-BACK "BASKET-WEAVE" RAYON BRAID—LACQUERED Solid—8837 Size 20 only Stranded—8838 Size 20 only
10000	500			HEAVY RUBBER PUSH-BACK "BASKET-WEAVE" RAYON BRAID—LACQUERED Stranded—8833 Size 18 only
1550	250			CELLULOSE ACETATE PUSH-BACK "BASKET-WEAVE" RAYON BRAID—LACQUERED Solid—8941 Size 20—8945 Size 18 Stranded—8943 Size 20—8947 Size 18—8938 Size 14
3800	96000			R-F HOOK-UP WIRE Solid—8834 Size 22—8841 Size 20—8861 Size 18—8863 Size 16 Stranded—8810 Size 22—8839 Size 20—8844 Size 18—8862 Size 16
9000	400			COLORUBBER Stranded—8880 Size 20 only
8650	425			VARNISHED CAMBRIC "BASKET-WEAVE" RAYON BRAID—LACQUERED Stranded only—8982 Size 20—8869 Size 12
0.0, .120				SHIELDED GRID WIRE Stranded only—8885 Size 20—Shield, 85% coverage
15000	0.0, .200			FIBERGLAS BRAID HIGH TENSION CORONA RESISTANT for Cathode-Ray Television Tube Leads Stranded Wire—8868 Size 18—Special High Tension Construction

*D. C. Insulation per ft. Immersed in Mercury



Here's How to Make a Good Connection

You save a lot of grief and customer dissatisfaction when you use the right hook-up wire—the construction that gives original equipment performance.

And now the right wires aren't hard to find. Belden, with years of close collaboration with the radio industry, provides a full line of replacement hook-up wires. More than that, complete information on their performance is included in the Belden catalog.

Don't go haywire—you'll make a good connection when you buy your wire from a Belden jobber.

Belden Manufacturing Company
4639 W. Van Buren St.
Chicago, Ill.

Belden Wire

FOR GOOD CONNECTIONS

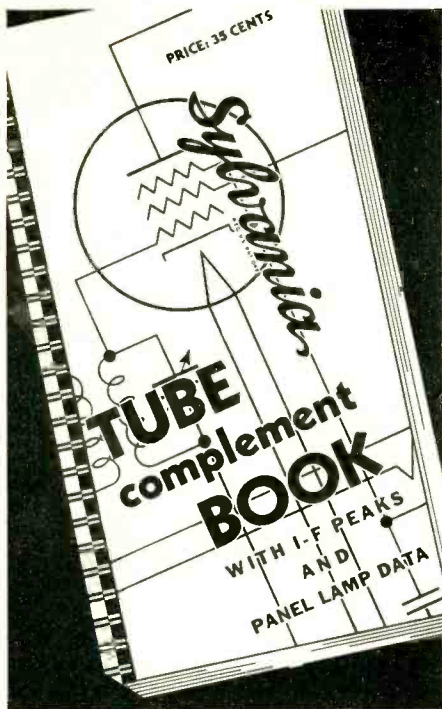

SERVICEMAN'S STANDBY

1941 EDITION . . .
NEW, IMPROVED
ONLY BOOK OF ITS KIND

272 Pages—16,730 Radio Models shown—including data on '41 receivers. Tube replacement information for 100,380 Tubes or Sockets. 586 Trade Names of receivers. Names and Business Addresses of 190 Receiver Manufacturers. Patented, Hold-Tite, Wire-O Binding.

The First and Only Compilation
Of Panel Lamp Numbers

Every Radio Serviceman should own one of these Sylvania Tube Complement Books. All the information you'll need—from the oldest set, up to and including the latest '41 models—is packed into those 272 pages. And the book is bound by the WIRE-O process. It opens flat and there's no danger of it falling apart or of the pages pulling out.

This valuable compilation, the only book of its kind in the field, is one of the 125 silent salesmen Sylvania has created to help you build a sounder, more profitable business. Write today for Sylvania's Tube Complement Book, enclosing 35c in stamps or coins, and for a full list of the surefire, tested, dealer aids. Some are free and some are available at a very nominal cost—all of them are designed to help you sell more, and make more! Radio Tube Division, Hygrade Sylvania Corporation, Emporium, Penna.

SYLVANIA

Set-Tested Radio Tubes

Also makers of Hygrade Lamp Bulbs, Hygrade Fluorescent Lamps and Miralume Fluorescent Light Fixtures

quite adept at placing the aeri-als, accessories, transmission line and outlets for any type of vessel.

The installation of the marine multicoupler-antenna system may be handled by radio men and shipyard electricians, following our layouts and using approved materials. The wiring may be done in conduit, along with the ship's electric wiring, or may be exposed, using the special lead-covered concentric cable and clamp supports.

Once installed, the system requires no upkeep over years of service. Because of the ideal radio entertainment made possible for the crew and officers, such an installation, along with the other appointments found on present-day cargo ships and tankers, pays for itself over and over again in a satisfied and loyal personnel.

SERVICEMAN'S DIARY

(Continued from page 8)

tassium in the tank last night, which did the trick. He was pointing out some of the new fish he had bought when—glory be—the Motorola cut out!

I dashed back and took a quick glance at the magic eye on the receiver. The size of the opening hadn't changed, so I knew the trouble wasn't in the r-f or i-f sections. I tried to measure the voltage at the plate of the first audio, but the volume immediately jumped to normal. This sometimes happens when there is a bad plate load resistor, so I cut a 0-1 millimeter in series with the plate lead to the first a-f tube and went back to Jerry and his fish.

"Now," I told him, "if you can get your trained fish to make that Motorola cut out again, I'll buy each of them a good dinner. And you, too!"

It took longer this time. In fact, I had to go back and jack up the line voltage to 130 before I got any results. But cut out again she did. And this time the trouble was definitely in the plate load resistor, because the millimeter reading dropped to practically zero. The resistor had opened. I replaced it and turned the set on again for final test.

"Jerry," I said, "I apologize for all the mean remarks I've made about your fish. They're wonderful! That was one tough job, and now it's fixed for—" And I suddenly noticed that the Motorola was no longer playing.

SHURE CARDIOIDS

★
**LICK FEEDBACK!
PERMIT
MORE VOLUME!**
★

In Night Clubs, Theatres,
Auditoriums, Ballrooms,
Bowling Alleys, Churches,
Outdoor Sports and many
other applications.



UNIDYNE

DYNAMIC



On every job—Shure Cardioids give you better audience coverage — with more volume—free from feedback, reverberation, background noise! These amazing microphones are dead at rear. They simplify microphone placement, solve difficult sound problems on the spot! "Unidyne" Dynamic (illustrated) in high and low impedance models. List Price \$42.50 and \$45.00 "Uniplax" Crystal (not illustrated), List Price, \$32.50.

See Your Jobber or Write for Catalog 153D



Shure Patents
Allowed. Cryst-
tal Microphones
licensed under
patents of
Brush Develop-
ment Co.

SHURE BROTHERS

225 W. HURON STREET CHICAGO, U.S.A.

"Listen!" I warned. "If you don't get those damned fish out of here—"

"Now, wait!" Jerry interrupted. "Don't you realize you may have fixed that set anyhow? Listen yourself. . . ."

And then, a strong voice, infinitely sad and solemn, but oh! so welcome to me, issued from the Motorola speaker, saying.

"This—is the National—Broadcasting Company!"

L-C CHECKER

(Continued from page 12)

alignment is correct at both frequencies.

5. If the correct i-f frequency has not been selected, the tracking may not be very good at points between 600 and 1400 kc. It is customary to secure exact tracking at three points; 600 1000 and 1400. The exact i-f frequency can be chosen by a method of cut-and-try. This is seldom necessary, since most receiver i-f peaks can be found in service manuals.

CHECKING FREQUENCY RANGE

The L-C Checker can be utilized as a signal generator in determining the frequency range of a receiver. In most cases a short length of wire connected to the antenna binding post will permit enough stray signal to be picked up from the L-C Checker. The characteristic hiss and "plop" noise should be heard as the dial of the L-C Checker is rotated through the frequency at which the receiver is set.

On superheterodyne receivers it is very important to check and make sure that a false response has not been secured at image frequency. Since the image will be twice the i-f frequency away from the true response, if the image is present, one should get both a strong and a weak signal as the L-C Checker is tuned across the receiver frequency setting. The lower frequency response on the L-C Checker scale, should be the stronger of the two, and is the correct one to use in checking the receiver range. Heretofore the image problem has not been so important in the broadcast band, but with many stations now on 910 kc, the situation is changed. With an i-f of 455 kc, it is readily seen that a receiver in close proximity to such a station will pick up a heterodyne whistle. At the higher frequencies—about 5 or 10 mc—the r-f selec-



It's Got to be Right to be **TRIPLET**

Nobody "bosses" Cliff Elliott, chief of the Triplet inspection line. Production is up, way up, but nobody puts the heat on "Inspection" for the slightest variation from the most hardboiled inspection scrutiny in the Industry. For it is an axiom in the whole Triplet plant—regardless of position or the pressure of orders—"It's got to be right to be Triplet."

Under expanded Industrial demand there continues to be no compromise in those rigid Triplet standards which have become the International Hallmark of Precision and Quality. For more information write Section 474, Harmon Avenue.

THE TRIPLET ELECTRICAL INSTRUMENT COMPANY
Bluffton, Ohio

SPRAGUE and NATIONAL DEFENSE

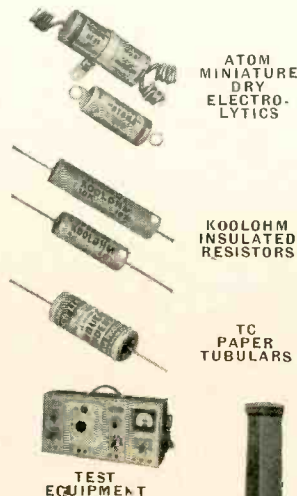

National defense needs come first! Sprague is putting them first—fully and wholeheartedly. One of our two big factories in North Adams, Mass., is now devoted almost solely to defense work.

Meanwhile, our other factory is turning out more Sprague Condensers, Kooiohm Resistors and Test Equipment for the Radio trade than ever before. Deliveries are prompt. Full Sprague quality is being rigidly maintained. Development work continues as in the past.

Thus, thanks to Sprague's size and unique facilities, we are able to put defense first—and still not neglect our long-time friends of the Radio profession.

SPRAGUE PRODUCTS COMPANY
North Adams, Mass.

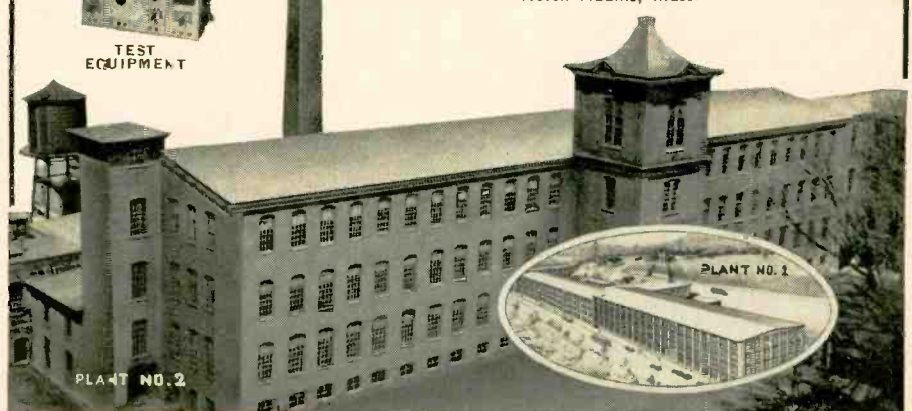

*Proved Protection
against Breakdowns*

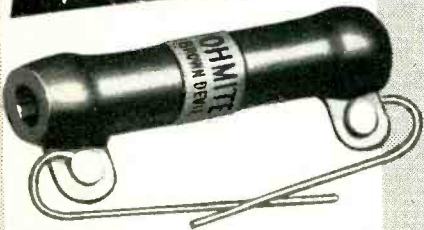

Brown Devils—
Extra-sturdy vitreous enameled
resistors for voltage dropping,
bias units, bleeders, etc. 10 and
20 watt sizes. Many stock values.



Adjustable Dividohms
—Handy for change of resistor
value or quick replacement.
Easily adjusted or tapped where
needed. 7 sizes, 10 to 200 watts.
Many stock resistances.

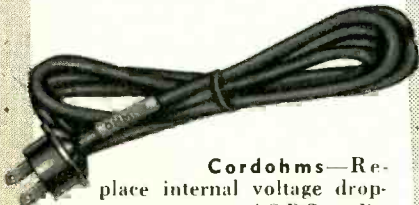

Cordohms—Re-
place internal voltage drop-
ping resistor in AC-DC radio
sets. Tapped cord for pilot light
also available. Eliminates gener-
ated heat from set.



**R. F. Power Line
Chokes**—Prevents R.F. currents
going out over the power line
and causing interference with
radio receivers. 3 stock sizes,
rated at 5, 10 and 20 amperes.

Send Coupon and 10c for New
Ohmite Ohm's Law Calculator

OHMITE MANUFACTURING CO.
4845 Flournoy St., Chicago, Illinois
10c in Coin enclosed.
Send Ohm's Law Calculator

Name

Address

City State

Occupation

Radio Service Dealer—April

OHMITE

RHEOSTATS RESISTORS TAP SWITCHES

tivity of the receiver is not sufficient to give a good image ratio, and it is mostly here that care must be taken to differentiate between the image and the correct response. It is necessary to keep in mind that the image and the correct response are always separated by twice the i-f frequency.

The L-C Checker may be used for checking the frequency range of signal generators. For instance, if the output of the signal generator is only about one volt, a very close check on the frequency coverage can be obtained by connecting the capacity coupling terminals directly to the output terminals of the signal generator, and when the L-C Checker is tuned through the frequency at which the signal generator is operating, the 6E5 will indicate a reduction in load or it will close slightly, instead of opening, as it normally does when power is removed from it by a tuned circuit. Naturally, the output controls on the signal generator should be set for maximum output, and this should be about one volt to register on the 6E5 resonance indicating eye.

The frequency determined by this method will have an error of about 5% near the high frequency end of each frequency range of the L-C Checker, since the coupling capacity of 5 mmfd. is shunting the tuned circuit of the oscillator. This shunting, of course, lowers the frequency somewhat below the calibration on the dial.

STATIC ALIGNMENT

Various tuned circuits of a receiver may be checked or aligned with the set dead. The individual circuits, starting with the radio-frequency input circuit, are first checked for resonant frequency. From this test the circuits out of tune or off resonance can be quickly found and returned to resonance so as to line up with the remainder of the set.

When capacity coupling is used for aligning a set, the coupling for some circuits may be too tight, thereby causing the oscillator to lock in step over a considerable range. To prevent locking of the oscillator a 10,000-ohm, 1-watt resistor should be connected across the tuned circuit. This reduces the effective coupling, hence prevents locking of the oscillator. In order to insure maximum accuracy it is desirable to allow the component parts of the L-C Checker to attain a constant temperature by turning on the switch at least fifteen min-

**It's Easier to Sell
Simplified Changers,
Low-Cost Recorders**

Customers spot the differences right away: the trim, streamlined appearance and easy, simplified operation of a combination equipped with the one-lever General Industries C-120 record changer. Just as readily, they want the saving in cost, and the better recording and reproduction you can offer when you demonstrate a C1-R70 low-cost home recording unit.

For installation in new instruments as well as in remodelling jobs, get the advantages of General Industries assembly-line lower costs, and 39 years of phonograph motor designing and building leadership.

Send for catalog and prices.

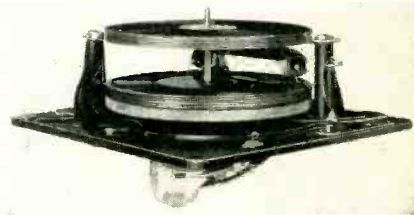

C1-C120 record changer. One lever adjustment sets changer for 10" or 12" records or manual playing. Direct-drive motor. Tangent-tracking crystal pickup.

The **GENERAL INDUSTRIES CO.**

Dept. 17

Elyria, Ohio

Order your Cutting and Play-back Needles from our affiliate, General Phonograph Mfg. Co., Putnam, Conn.

for

FM

**a new Cinaxial
Speaker System**

for absolute fidelity of response. Model FM-12 will fit any standard 12-inch baffle. Controlled by accurately calibrated network. Single unit holds all transformers and condensers. Lists at only \$42.50.

Write for special bulletin

**CINAUDAGRAPH
SPEAKERS, Inc.**

921 W. Van Buren St.
Chicago, Ill.

**LET THE HIGH LINES
MAKE PROFITS FOR YOU!**
**SELL GTC
PORTA-POWER**
CONVERTS BATTERY OPERATED
RADIOS TO ALL-ELECTRIC

MODEL "P"
For 6 volt radios
"Twin-Powered"

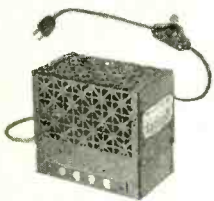

Converts 98% of all 6 volt radios. Vibrator disturbance is eliminated. High fidelity performance assured. List price \$13.95.

MODEL "L"
For 2 volt radios

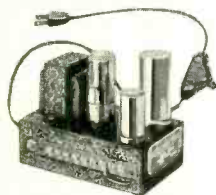

Supplies "A", "B" and "C" power to 4 to 8 tube battery-operated radios using 2 volt tubes. List price \$9.95.

MODEL "U"
For 1 1/2 volt portable or farm radios



Powers any portable or battery radio using 1 1/2 volt tubes. Provides "A" and "B" power. List price \$7.50.

MODEL "G"
For 1 1/2 volt radios of 4, 5, or 6 tubes



For 1 1/2 volt radios of 4, 5, or 6 tubes requiring more power than Model "U" provides. List price \$9.50.

When you reset radios with push-button tuning be sure to mention GTC Porta-Power for electrifying Portable and Rural Battery Radios.

GENERAL TRANSFORMER CORP.
254 W. VAN BUREN ST. • CHICAGO, ILLINOIS

utes before attempting to use the L-C Checker as a frequency source. After this warming-up period, the maximum frequency drift should be well within the normal tolerance of such instruments, more specifically since the L-C Checker is independent of line voltage variation.

In measuring the resonant frequency of i-f transformers, care should be taken to short-circuit the free winding, that is, the winding which is not connected to the Checker, to prevent the coupling back of the circuit. By doing this, each winding is measured at its own frequency and when this arrangement of connections is used for alignment it is possible to align each winding independently of the other.

In many vicinities in the country there are districts in which the power supply is a.c. and d.c. A serviceman whose shop is in a d-c district and does not have a source of a-c cannot service a-c receivers, since it is impossible for him to operate such receivers unless he goes to the expense of buying a rotary converter. With the L-C Checker, however, it is possible for him to align a receiver approximately, although he has no a-c available for operation.

In aligning a receiver the procedure is essentially as follows: Check the various components of the receiver for continuity or shorts by means of a volt-ohmmeter. Upon ascertaining that there are no short circuits or open circuits, we can assume that the receiver is in operating condition except for alignment.

In checking the components, all of the resistors should be checked by the ohmmeter for their proper values. The capacitors should be checked for capacity value by the L-C Checker, while the shorts in a capacitor can be checked by the ohmmeter. The individual circuits of the receiver can then be aligned by means of the L-C Checker.

This is done by coupling the L-C Checker to the circuit to be measured. For example, suppose the antenna circuit is to be checked first. If the antenna coil is in the open, the output loop can be held over the coil by coupling to the antenna circuit. The L-C Checker is then tuned and the frequency of the antenna circuit is noted by an indication of the 6E5. If the coupling is tight, the eye should open slightly and lock in; that is, the eye should open for a space of several kc. as the L-C Checker is tuned.

**"Bottleneck"
IN YOUR BUSINESS..**

**BECAUSE OF INCOMPLETE
SERVICING DATA?**

Is your production choked up—are your operating costs per hour too high—do you find yourself late on promised delivery dates? Trouble shooting is a bottleneck in any service shop that tries to "get by" without complete servicing data.

In successful shops, where work flows through smoothly, where hour costs are low and profits are high, you will find Rider Manuals. Speed up your trouble shooting—eliminate bottlenecks in your production—get all twelve Rider Manuals . . . Today!

**What You Get in
RIDER VOL. XII
MANUAL**
1648 PAGES *Just Out!* \$10.00

"Clarified Schematics"

Covering sets made since May 1940, Volume XII contains "Clarified Schematics" breaking down over 200 models whose original schematics are extremely involved. From them you can see which coils, condensers, resistors and switch contacts are used in the i-f, mixer or oscillator sections of the complete circuit.

Vital Facts

More than just "wiring diagrams," Rider Manuals give data on i-f peaks, operating voltages, alignment frequencies, parts values, voltage ratings of condensers, wattage ratings of resistors, coil resistance data, dial cable adjustments, etc., etc. Cash-in-hand information, all in one place.

Complete Index

Covers Volumes XI and XII. Cross-indexed so you quickly locate facts on any set.

"Successful Servicing"

Rider Manual owners receive "Successful Servicing" magazine. Keeps servicemen up-to-date on developments and carries news from the "Successful Servicing" Laboratory. If you do not receive it write and you will be placed on the list.

JOHN F. RIDER PUBLISHER, Inc.
404 Fourth Avenue, New York City
Export Division: Roche-International Elec. Corp., 100 Varick St., New York City.
Cable: AIRLAB

**For Complete Information
RIDER MANUALS
Now in 12 Volumes!**



The Thriftiest Electrolytics

- Believe it or not (with due apologies to Ripley) the thriftiest capacitor you can use is offered by these full-sized, heavy-duty, Aerovox metal-can electrolytics.

With honest-to-goodness full-rated "dry" electrolytic sections, and with large can surfaces for prompt and effective radiation of generated heat, these units stand up to hour-after-hour operation, day in and day out, for years of service. If you're servicing or building equipment on that basis, then by all means use these full-sized metal-can Aerovox electrolytics. They will prove most economical—in the final reckoning.

Ask for Them!

- Your local Aerovox jobber can supply you with these full-sized metal-can electrolytics for your quality work. Also with those inexpensive midgets and cardboard-case electrolytics when you are talking price. Ask for latest catalog—or write direct.



When this occurs, the coupling should be loosened by moving the output loop back from the antenna coil until the eye will open and close as the pointer is moved over the scale.

If the antenna coil is shielded, capacitive coupling can be used by connecting the red binding post of the L-C Checker to the grid of the tube connected to the antenna coil. This may be the first detector or mixer, or the r-f amplifier. The L-C Checker is then tuned as before and if inter-locking is noticed, the coupling must be decreased by inserting in series with the output lead a 0-10 mfd trimmer condenser (or by clipping the lead to the insulation on the grid lead rather than on the grid lead itself. At the high frequency end of the band this will give sufficient coupling to cause an indication on the 6E5 eye of the L-C Checker). The capacity of the trimmer is then adjusted until it is sufficient to cause a large indication on the 6E5, but not great enough to cause inter-locking of the circuits. At this time the L-C Checker can be set to the frequency at which the set is to be aligned, and the trimmer of the antenna stage adjusted for maximum response. The same can be done to each r-f stage of the receiver, remembering that the oscillator frequency is equal to the signal frequency plus the i-f frequency.

The actual adjustment of the tuned circuit is simplified considerably by the fact that it is possible, by means of the L-C Checker, to determine the exact frequency to which the circuit is tuned before any adjustments are made, thus indicating the direction in which the adjustments are necessary.

After a receiver has been aligned in this manner, it is operating satisfactorily, although it is not completely aligned. For a final alignment the power must be on. This

final alignment can be performed either at the serviceman's bench or at the customer's home, since it merely consists of slightly adjusting the various trimmers for maximum efficiency.

CIRCUIT COURT

(Continued from page 21)

is supplied through the cutter transformer.

The 47,000-ohm resistors R37 and R38 serve to isolate the two transformers, the primaries of which are essentially in parallel, while still retaining a simplified switching system. Besides, when the switch is in the cutting position, reduced audio output is supplied to the speaker for monitoring purposes.

PORTFOLIO

(Continued from page 18)

condensers in the avc network to the same potential. When we suddenly tune to a weak station, producing only a small avc voltage, it takes a moment or two for the condensers in the avc system to lose a portion of the high negative potential which they had acquired when the strong station was being received. So long as the condensers retained this high negative voltage, the sensitivity of the receiver was lowered, consequently the weak station was momentarily very weak, perhaps inaudible. But as soon as the condenser potential had become readjusted, the strength of reception of the weak station was greatly increased.

Another familiar manifestation of this lag is observable in tuning quickly from a weak station to a very strong one. If the set blasts momentarily on the strong signal,

Cash-In on Frequency Modulation

With the New HOWARD Chassis

The recently announced line of famous HOWARD Chassis is making real money for hundreds of progressive radio men. Now, HOWARD makes available the most modern of all chassis—the 718-FM. Complete tuning range includes the Frequency Modulation band from 41 to 50 MC and three AM standard broadcast and short wave bands from 540 KC to 22 MC. Has full fidelity, push-pull 12 watt audio system with separate bass and treble controls, SPECIAL 12" Jensen electro dynamic speaker, push button and flywheel manual tuning control, phono "off-on" switch and dozens of other HOWARD quality features. This timely and unchallenged chassis value can mean big profits for you. Send at once for full details on the complete HOWARD replacement chassis line. It will pay you well.

America's Oldest Radio Manufacturer

HOWARD RADIO COMPANY
1731-35 Belmont Av., Chicago, Ill. - Cable Address: HOWARDCO, USA

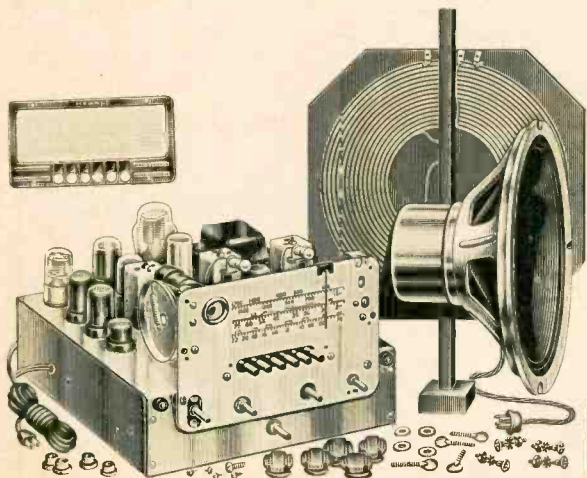

SOLAR CONDENSER
Quick-check Analyzer
MODEL QCA

- ✓ Measures Capacity
- ✓ Indicates Leakage
- ✓ Shows Insulation Resistance
- ✓ Indicates Power Factor
- ✓ Affords Dynamic Checking for

OPENS . . . SHORTS
INTERMITTENTS

- ✓ Acts as Continuity Meter
- ✓ Indicates R. F. Impedance



Model QCA-1-60
 Complete Analyzer, ready to operate . . . ONLY \$18.90
SOLAR MFG. CORP., Bayonne, N. J.

INSULINE

MANUFACTURERS TO THE
 RADIO INDUSTRY SINCE 1921

... featuring ...

- Metal Cabinets, Chassis and Panels
- Plugs — Jacks — Neutralizing Tools
- Test Leads — Punches — Circle Cutter Tools
- Dials — Knobs — Switches
- Condensers — Chokes
- Radio Hardware and Essentials
- Auto Antennas and Accessories

 Also Parts Made to Your Own Specifications



Write for Catalog

INSULINE CORP. OF AMERICA
 30-30 NORTHERN BLVD.
 LONG ISLAND CITY, N. Y.

before settling down to the normal level, we may rest assured that it is due to the time required for the condensers to charge up to the full avc voltage which, once reached, reduces the sensitivity of the receiver so that normal output results.

The time required for these condensers to charge and discharge is determined by the time constant of the circuit, which in turn is equal to the resistance multiplied by the capacity. If the resistance is expressed in megohms and the capacity in microfarads, the result is in seconds, thus:

$$\text{Time constant (in seconds)} = RC$$

Actually there is a die-away factor which is sometimes included in the formula, but this may be omitted if we remember that the equation above represents the time required for a condenser to lose 63% of its charge, when being discharged, or, if being charged, to acquire 63% of its final charge. In avc systems, it is considered good practice to make this time constant not greater than 1/20th second. Why not make it less, if a long time constant causes trouble? Simply because we have to filter out the audio voltage, and that requires plenty of filtration. Chokes could be used, but they are too expensive.

In figuring the time constant, we add together all the values of resistors in the network to determine R and all the capacity values to determine C. Thus, if the sum of R1, R2, R3 and R4, in Fig. 5-A, comes to 1 megohm, and if C2, C3 and C4 equals .05 mfd, the time constant is 1 x .05, or .05 second, which is 1/20th second. If any one of the condensers in the avc network were increased in value, the time constant would be increased proportionately. This should be remembered in making replacements. Don't stick in an 0.1-mfd tubular on the assumption that too much capacity is always enough; it just doesn't work out in this type of circuit. And the same applies to the resistors—use the specified values and avoid headaches.

NEW CATALOGS

Allied Radio Corp., Chicago, Ill., have released their 180-page 1941 Spring Catalog with covers in direct-color photography. Includes 57 new Knight radio models, 25 sound systems, 100 pages of parts and test equipment. Also Ham equipment, kits, fluorescent lighting, etc. Copy free.

Utah Radio Products Co., Chicago, Ill., has issued their 1941 Catalog for dealers.

SUNCO
Sell CARILLONS
MUSICAL TOWERS



THE PROFIT ON SALES IS BULKY

Our steady advertising in leading church publications, and our direct mail, brings us live inquiries for Chime Carillons, High Power Automatic Reproducers, and Musical Tower Recordings. These we pass on to the rated sound men affiliated with us, to turn into profits for themselves. These profits are substantial for Carillons, Musical Towers and Belfry Chimes run into money.

If you are interested and preferably rated in Dun & Bradstreet, write us at once. We will send literature and confidential information definitely interesting.

A New Big Field for You

Carillons are bought by individuals and organizations who are sincere in their desire for service and community welfare. They are generous. Into this market the Sunco representative comes with equipment that can be, and is, guaranteed to equal in power and beauty of performance, anything of similar nature, costing ten times its price.

We also produce special recordings of sacred and semi-sacred music of high quality, and have a large repertoire available. This gives our representatives an exclusive advantage, for recordings of this quality and variety are obtainable anywhere. Write for prospectus and list of recordings today.

SUNDT ENGINEERING COMPANY
 4789 N. Ravenswood Ave. Chicago, Ill.



BRACH
Antennae

Automobile
 Home — All types
 F-M Systems
 Television
 Police • Marine
 Multiple Systems
 Complete Kits
 Accessories

Made by World's Oldest and Largest
 Manufacturers of Radio Aerial Systems

L. S. BRACH MFG. CORP.
 55 DICKERSON STREET
 NEWARK, N. J.



jobbers, servicemen and manufacturers. Covers the company's complete line of speakers, vibrators, replacement transformers and **Carter** parts. Handy data included. Copy free.

Aerovox Corp., has compiled its 1941 General Catalog in concentrated or tabloid form so as to save time in seeking essential data. Covers the line of electrolytic, paper, oil, exact-duplicate replacements, transmitting and other condensers, as well as the L-C Checker, Capacity-Resistance Bridge, etc. Copy free from local jobber or Aerovox Corporation, New Bedford, Mass.

Radio Warehouse Market, P. O. Box 3366, Akron, Ohio, have available their Catalog No. 7, at no charge.

SPOT NEWS

Simpson Enlarges—Although it is only five years since the present **Simpson Electric Company**, Chicago, came into the field with a new line of panel instruments and testing equipment, news has just broken that manufacturing operations have outgrown the original plant, and that a new building is under construction which will ultimately double the capacity of the present factory.

Stephen Nester, 799 Broadway, New York, N. Y., announces the formation of a new



RADIOTECHNIC LABORATORY announces a new type radio tube and battery tester:

A tester that will never have to be modernized at a price within the reach of all servicemen.

- ★ Exclusive RTL patented short test and output test.
- ★ Simple to operate; very accurate.
- ★ PMT switch system has over 40,000 combinations.

WRITE TODAY for complete information on our special proposition to servicemen.

The Radiotechnic Laboratory
EVANSTON, ILLINOIS

manufacturing and selling organization which will produce a complete line of American-made recording and play-back needles.

Presto Recording Corp., 242 W. 55th St., New York, N. Y., is offering to assist servicemen in establishing a disc business for themselves by furnishing disc order cards imprinted with the name, address and phone number of the service organization, which can be left with the set owner at the time his radio-recorder is tested or repaired. The cards are offered up to one hundred, free of charge.

NATIONAL DEFENSE FRONT

Major Armstrong has offered the Army free use of his f-m patents for defense purposes. It is rumored that the Army will make use of this system of communication for special purposes.

Radiowatch—Establishment of special national defense "listening posts" to record, translate, transcribe and analyze foreign short-wave broadcasts is being undertaken by the **Federal Communications Commission** in cooperation with the **Defense Communications Board**.

A 24-hour watch for subversive and other pertinent radio propaganda from abroad is being set up at primary monitoring stations strategically located throughout the U. S. and its possessions.

A picked force of 350 technicians, translators, clerks, propaganda analysts and other experts will work in eight-hour shifts to keep abreast of all overseas transmissions which may involve propaganda intended for persons in this country or neighboring countries.

After being recorded in the field, all this material will be coordinated and studied at Washington.

Veteran Operators—Over thirty members of the Chicago Chapter of the **Veteran Wireless Operators Association** attended a dinner at the Lake Shore Athletic Club in that city to discuss their part in national defense and to further the progress of the Chapter.

The retiring chairman **George I. Martin**, of RCA Institute presented a life membership certificate to the new chairman, **W. J. Halligan**, president of The Hallicrafters Company.

Sprague All-Out On Defense—Faced with a particularly heavy influx of national defense orders, some of them calling for special machinery and methods, the **Sprague Specialties Co.** and **Sprague Products Co.**, of North Adams, Mass., have found a practical solution to the problem of giving these orders priority while still not neglecting its regular radio business.

Several years ago, Sprague acquired a second factory about a mile from its original plant. This is being devoted almost exclusively to the defense business.

Results have proved highly satisfactory, and in many instances delivery dates have been bettered. Meanwhile, the original plant is turning out products for the radio trade.

APPOINTMENTS

R. J. Higgins, for the past five years in charge of sales promotion for **Hallicrafters**, Chicago, has been appointed Director of Advertising and Sales Promotion.

Walter F. Marsh has been appointed to the position of Sales Manager, Chicago Metropolitan District, of **Allied Radio Corp.**

National Recording Supply Co., Hollywood has been appointed national distributors for Alco blank recording discs, manufactured by **Record Sales Co.**, Los Angeles.

Lear Avia, Inc., New York, announce the appointment of two new Learradio service dealers. These are: **Hobley-Maynard Air Service, Inc.**, New Orleans Airport, New Orleans, La., and **Carl W. Ulrich**, 633 South 5th St., Louisville, Ky. Mr. Ulrich's field station will be based at Bowman Field, La.

F. H. Brown, Hollywood, has been appointed west coast factory representative for **Federal Recorder Co.**, New York. He will cover seven western states, with office at 1065 Vine St., Hollywood.

Robert Reid, formerly sales manager of **Radiotone**, Los Angeles, has been appointed western sales manager for **National Recording Supply Co.**, Hollywood.

L. R. Barbley, formerly with **Packard-Bell**, has also joined National sales force to handle dealer contacts.

BOOK REVIEW

VACUUM TUBE VOLTMETERS, by **John F. Rider**. Stiff cloth cover, 5½" by 8½", 179 pages, well illustrated. Published by **John F. Rider Publisher, Inc.**, 404 Fourth Ave., New York, N. Y. Price \$1.50.

Rider, like President Roosevelt, has a keen sense of timing. To anyone with their wits about them, it is becoming increasingly evident that the vacuum-tube voltmeter, and variations of it, will play a big role in radio and electronic servicing for years to come. The time is ripe for an authoritative book on the subject.

Like most of Rider's books, **Vacuum Tube Voltmeters** is a compilation of the theoretical and practical, and is the result of extended reference work and laboratory experiment.

The eleven chapters cover Fundamentals of Vacuum-Tube Voltmeters; Diode- and Triode-Type Units; Slide-Back Types; Rectifier-Amplifier Vacuum-Tube Voltmeters; Tuned Units; Audio and Logarithmic Types; Units for d-c Voltage, Current and Resistance Measurements; Design and Construction of Vacuum-Tube Voltmeters; Calibration and Testing; and Applications.

An Index, and a Bibliography consisting of 145 references, has been included.

The book is highly recommended to servicemen, electronic engineers, students and librarians.

*** QUALITY**

*** PERMANENCE**

*** DEPENDABILITY**



... **ALL** Present a
United Front to make
Centralab
RESISTORS
 the **Only** Resistor
 in **ANY** Emergency!



* **QUALITY** backed by years of experience, engineering supervision and the best of materials.

* **PERMANENCE** of resistance values under high temperatures and excessive loads.

* **DEPENDABILITY** proved by countless tests and constant use for over twelve years.

● For service work, amateur needs or industrial equipment, Centralab Resistors will serve every purpose. The hard-as-stone insulating jacket and conducting core of ceramic are fired together at 2500° F. into a durable shockproof unit as ageless as stone . . . heat resisting and humidity proof. For every occasion and every use specify Centralab Resistors.

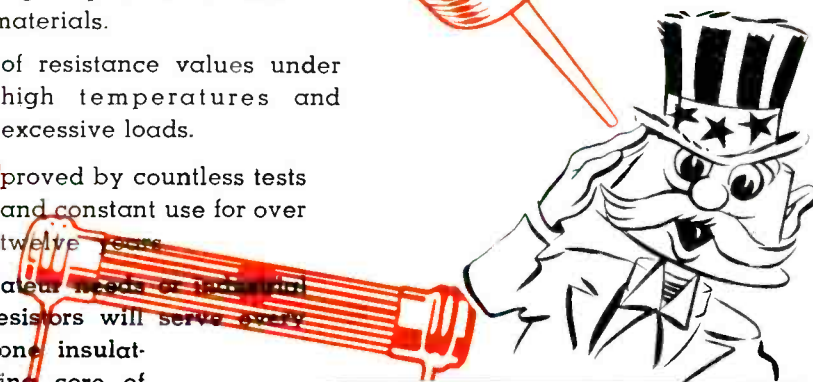

Centralab

Division of Globe-Union Inc.

MILWAUKEE, WIS.

2 more of NATIONAL UNION'S *50,000 Reasons Why!

POPULAR CONDENSER
ASSORTMENT with
TOOL SUPPORTER

2.75
TAKES
BOTH

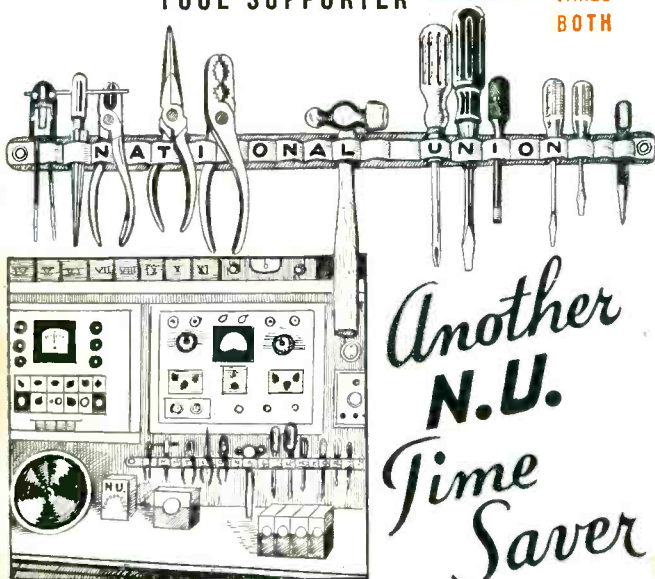

Another
N.U.
Time
Saver

Tool Supporter is 24" long.—holds 20 tools.—sturdily constructed.

THE basic tools of your profession always at your finger-tips — No more hunting — no more wasted time — your tools are where you want them — when you want them.

FOR A LIMITED TIME ONLY

Get this POPULAR CONDENSER ASSORTMENT WITH TOOL SUPPORTER — \$5.25
TOTAL VALUE \$6.10

This fine assortment of popular type N.U. Condensers will move fast, give you a good profit and insure the good will of your customers. If you're already using N.U. condensers, you'll be sure to snap up this offer in a hurry. If you don't know yet how really good N.U. condensers are, here's a great opportunity to try them! The assortment you get on this limited offer consists of:

1—AT1025 1—AT2015 2—AT8450 1—AT2215
2—T601 3—T605 3—T610 1—T625

See your N. U. Distributor or write

AND NOW

A BATTERY MERCHANDISER

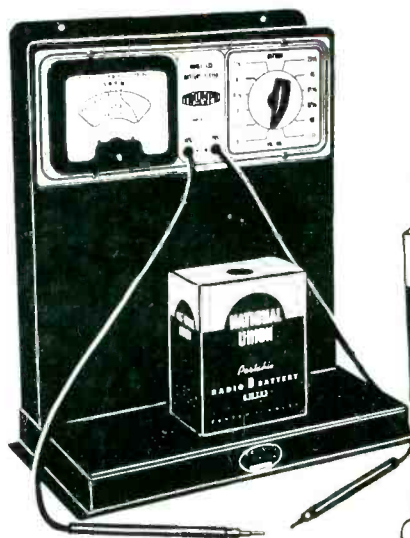

**Sells More Batteries
•
Lets Your Customer See**

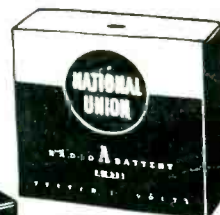

win trade from drug stores and filling stations

- Set Switch for Voltage
- Read condition of Battery on percentage of useful life meter
- Made by TRIUMPH
- For Counter use or Can Be Mounted on Wall

Only \$8.00 Deposit

Delivery made at once on \$8.00 deposit and order for \$10.00 worth of batteries, dealer prices. Deposit refunded on purchase of 430 points. All purchases of N.U. tubes, condensers and batteries count as points.

**MAKE MORE MONEY WITH N.U. BATTERIES
Sold Exclusively to Radio Service Dealers**

The N.U. line of radio replacement batteries has been developed exclusively for radio service specialists. All popular types are included. Batteries are attractively packaged in rugged boxes incorporating the standard N.U. color scheme—black and two shades of green.

N.U. Batteries are carefully manufactured from the finest materials obtainable and are fully guaranteed against defects in workmanship and materials. All types equipped with standard plugs for quick and easy replacement installation.

Thoroughly moisture proof for satisfactory and reliable service under all climatic conditions.

Install N.U. replacement batteries for more hours of reliable service and satisfied customers.

N.U. brings you a line of replacement batteries on which you can

make your full radio service profit. It is not necessary now for you to test sets and install batteries without adequate compensation for your time and knowledge.

N.U. has been identified with the radio service dealer and his problems since the beginning. You can definitely make more money handling N.U. products.

SEE YOUR DISTRIBUTOR OR SEND COUPON

NATIONAL UNION RADIO CORPORATION
57 State Street, Newark, N. J.

I am interested in your new Battery Merchandiser calling for only \$8.00 deposit. Please send more information.

Please have salesman call. RSD-1-11

Name

Street Address

City



Over a 10 year period Servicemen have earned through their purchases of N. U. tubes, batteries and condensers, in excess of 50,000 pieces of high calibre test bench equipment.

© 1941 N.U.R. Corp.

NATIONAL UNION RADIO

57 STATE STREET, NEWARK, N. J.

Corp